

NIAGARA 5000

Low-Z Power | Noise-Dissipation System

Quick-Start Guide



The Niagara 5000 owner's manual contains considerable information to ensure optimal performance, troubleshoot both common and rare system interactions, and is a great primer to the technology that makes this unit so unique. However, we appreciate and respect your valuable time. At the very least, we humbly ask that you follow this quick-start guide.

- If the Niagara 5000 has been exposed to excessive rain, flooding, fire, or has sustained considerable physical damage, we ask that the unit be returned. Do not attempt to energize the unit or connect equipment to it!
- The power source to which the Niagara 5000 is connected should be 120-127VAC single phase nominal voltage, 20 amps (current capacity RMS). However, the Niagara 5000 will operate very well with a 15-amp service outlet. For proper operation, the Niagara 5000 requires a safety ground (supplied via the power utility AC wall outlet).
- The Niagara 5000 may be placed on any table, cabinet, shelf, or floor. When rack-mounting is required, the four threaded feet may be removed with a standard Phillips screwdriver.
- Placement or proximity to other components is not critical, and, under standard use, the Niagara 5000 does not produce any appreciable heat.
- Once the Niagara 5000 is placed, an appropriate 20-amp-rated AC cord must be connected to the rear-panel AC inlet (IEC-C20) connector. The AC cord must have an IEC-C19 female-end connector and a grounded male 120VAC Edison/NEMA plug for use in North America or Taiwan. For the best performance and proper Ground-Noise Dissipation, we recommend AudioQuest AC cords.
- **Connecting AC cables to the Niagara 5000's NRG Edison AC outlets – WARNING!** The AudioQuest NRG-Edison AC outlets feature the strongest grip of any commercially available AC outlet in history. They will require slow and careful “wiggling.” When either inserting a plug into these receptacles or removing an AC cord's male plug from the receptacles, gently move the male AC cord's plug from side to side while providing an even forward or backwards pressure.
- **High Current/Low-Z Power Banks:** There are two High Current/Low-Z Power banks (labeled “1” and “2”) with two AC outlets each. The outlets feature our Transient Power Correction Technology, and are designed to enhance the performance of power amplifiers via our circuit's low-impedance transient current reservoir. Power amplifiers, monoblock amplifiers, integrated amplifiers, powered receivers, or powered subwoofers should **only** be connected to these four outlets.
- **Power Correction Switch:** This rear-panel-mounted switch **MUST** be set in the **ENGAGE** position, regardless of the equipment (line-level, digital, video components, or power amplification) that is connected to the Niagara 5000. It may not function properly otherwise. If necessary, see user manual set-up for more detailed information. (Otherwise, please place this switch in the **ENGAGE** position.)
- **Ultra-Linear Noise-Dissipation System Power Banks:** Typically, these are for all line-level, digital, and video products. There are four banks (labeled “3,” “4,” “5,” and “6”) that utilize this technology within the Niagara 5000. Further, each bank employs ground-noise isolation that is independent from the others.
- **I hear a slight buzzing sound coming from the Niagara 5000. Is it damaged?** No, it's not damaged (or, at least, damage is very unlikely). If you're in an extraordinarily quiet room and you hear this buzzing sound only when in relatively close proximity to the Niagara 5000, or only when you place your ear next to the unit, the buzzing is normal and cannot be entirely eliminated (though easily detectable levels are rare). See the Niagara 5000 manual for detailed information about high-level harmonic AC line distortion and its ability to make some of the circuits suffer from mechanical ringing, or *magnetostriction*.

audioquest®

Suggested AC Connections

1

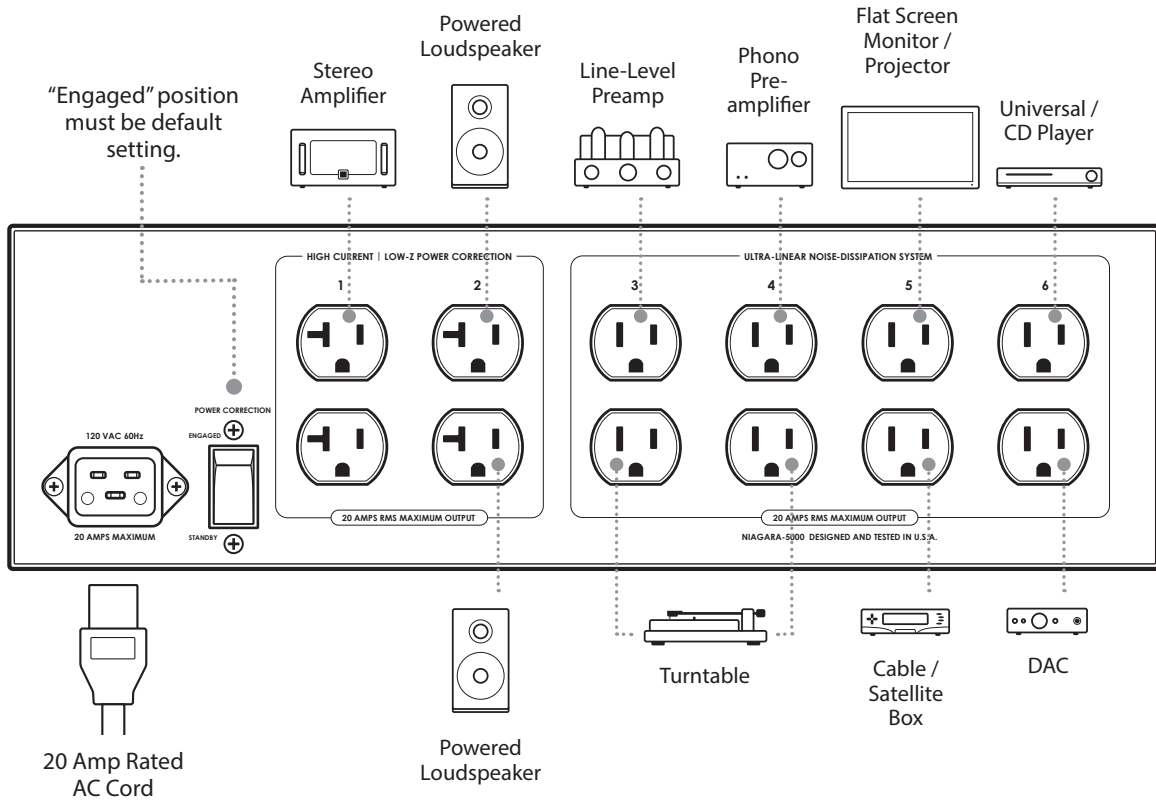

2

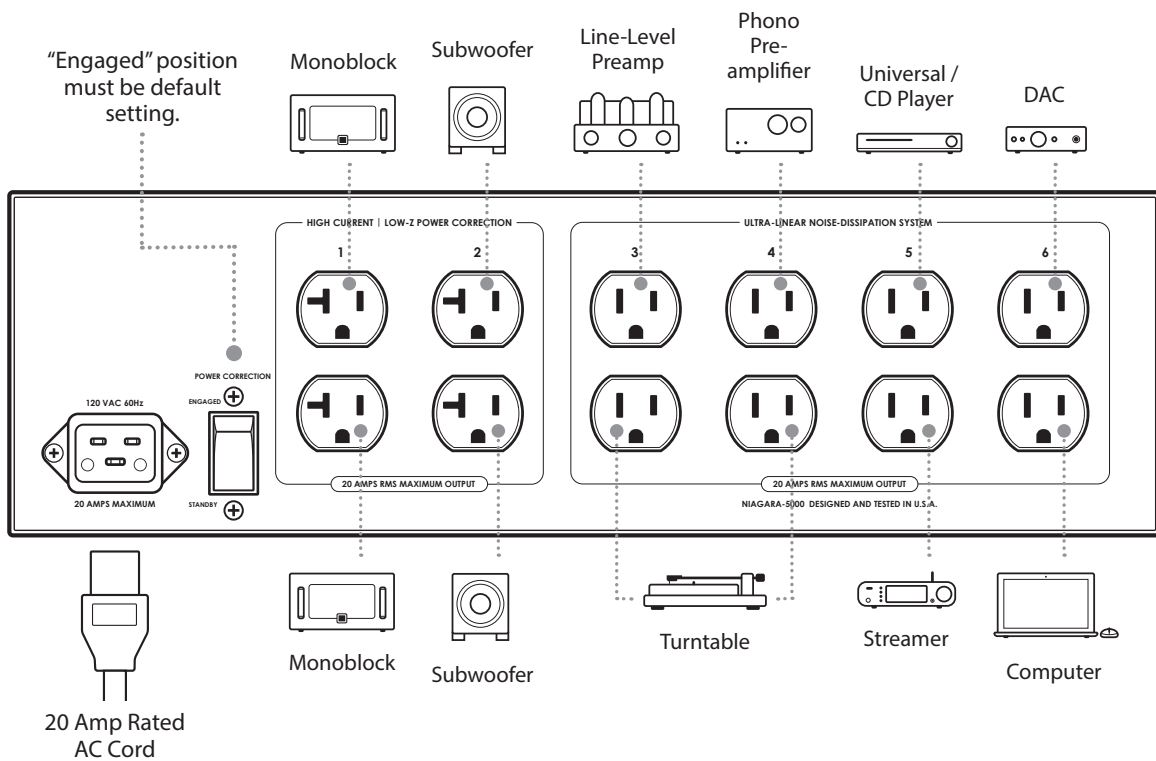

Note: Banks 3 through 6 are subject to many variables and circuit conditions, so experimentation for best results is encouraged. Power amplifiers **must** be connected to banks 1 or 2.