

CONTENTS

INTRODUCTION	1
DESIGN INNOVATION	2-4
INSTALLATION	4-5
CONNECTION TO THE AMPLIFIER	6
POWER SUPPLY	6-7
CONTROL AND CONNECTION ILLUSTRATIONS	8-9
TRANSPORTING YOUR TURNTABLE	9
CARE OF THE TURNTABLE	10
OWNERS LOG	11

INTRODUCTION

The **RP6** has been designed and engineered to achieve outstanding performance way beyond the expectations of a product at this price point. Excellent build quality, reliability and ease of use combine to make a product which, if used correctly, will offer you a lifetime of musical enjoyment.

Omitting unnecessary gimmicks allows us to concentrate the manufacturing costs on the high quality parts necessary to reproduce music accurately. The **RP6** is fitted with a hand assembled **RB303** tonearm, precision main bearing and a low vibration low noise 24V motor assembly which is individually hand tuned to its circuit to further reduce vibration.

The minimalist design of the Rega **RP6** and the use of extremely high quality components ensure that your turntable should last for many years. The tips in this manual will help increase the life of your turntable and ensure optimum performance.

DESIGN INNOVATION

DB TECHNOLOGY (DOUBLE BRACE TECHNOLOGY)

"Mass absorbs energy - lost energy equals lost music"! Rega has pioneered the use of lightweight rigid plinths. Clever use of lightweight particulate core with a highly rigid phenolic resin skin became the foundations of the high level of performance achieved by the now iconic Planar turntable range. The latest generation of Rega turntables takes this design philosophy to the next level. A super lightweight plinth combined with a phenolic resin double brace mounted specifically where the increased rigidity is required (between the tonearm mounting and the main hub bearing) forms a structurally sound "stressed beam" assembly. This rigid plinth design prevents energy absorption and unwanted resonances which will add unnatural distortions to the music. Equally, heavier mass can transfer more unwanted energy such as motor or bearing noise directly into the rotating record. The use of braces instead of the complete skin allows double thickness phenolic resin in these key areas while providing further weight reduction to the plinth which directly addresses the issue of mass absorption and unwanted energy transmission.

PLATTER

The **RP6** features an innovative two piece platter design constructed from float glass. Manufactured using a complex and labour intensive invisible UV curing bond technique the secondary ring platter is permanently bonded to the underside of the main platter. The extra ring adds mass to the outer circumference which increase the natural flywheel effect of the platter improving speed stability, accuracy and consistency.

HUB

The aluminium top sub platter is manufactured to the highest tolerance and uses a six point mounting system to ensure the platter and vinyl is presented as flat as possible to the stylus.

MOTOR

The motor is a high specification, 24V twin phase synchronous unit which has the anti vibration circuit hand tuned to each motor and is controlled by Rega's unique and innovative **TTPSU** power supply. The motor drives the computer-numerically-controlled (cnc) machined pulley and sub platter/hub-bearing assembly via the belt drive.

TO NEARM

Designed using the latest 3D CAD technology the new **RB303** is the culmination of more than 30 years of tonearm design experience. Due to advances in technology we have been able to fine tune the iconic **RB300** tonearm design. Featuring a brand new tube which has increased rigidity to the bearing housing, arm carrier and headshell coupled with intelligent redistribution of mass, ensure this arm will exhibit fewer points of possible resonance. Extreme stability with almost friction free movement from the high precision bearing assemblies guarantee to gather more information from your vinyl than ever before.

INTERCONNECTS

We have used the highest quality, purpose designed high current power connectors. The phono plugs and interconnect cable are low noise, wide bandwidth genuine professional products and are the best available for the job. Do not attempt to fit any other wires or cables.

INSTALLATION

SETTING UP YOUR RB303 TONEARM

With the cartridge mounted correctly and set up using the alignment protractor supplied, ensure that the tracking force control and bias adjustment slider are set to zero. (Pull the bias adjustment fully out to set zero). Slide the balance weight along its shaft until the stylus is "floating" just 1mm clear of the record.

The recommended tracking force can now be applied via the tracking force control shown on page 5. Always use a force which corresponds to the upper limit of the cartridge makers recommended range. Push the bias adjustment slider to the same number as the tracking force control. ie a recommended 2.0g tracking force = 2.0 on the bias slider. Ensure the cartridge mounting hardware is fitted correctly as shown on page 5.

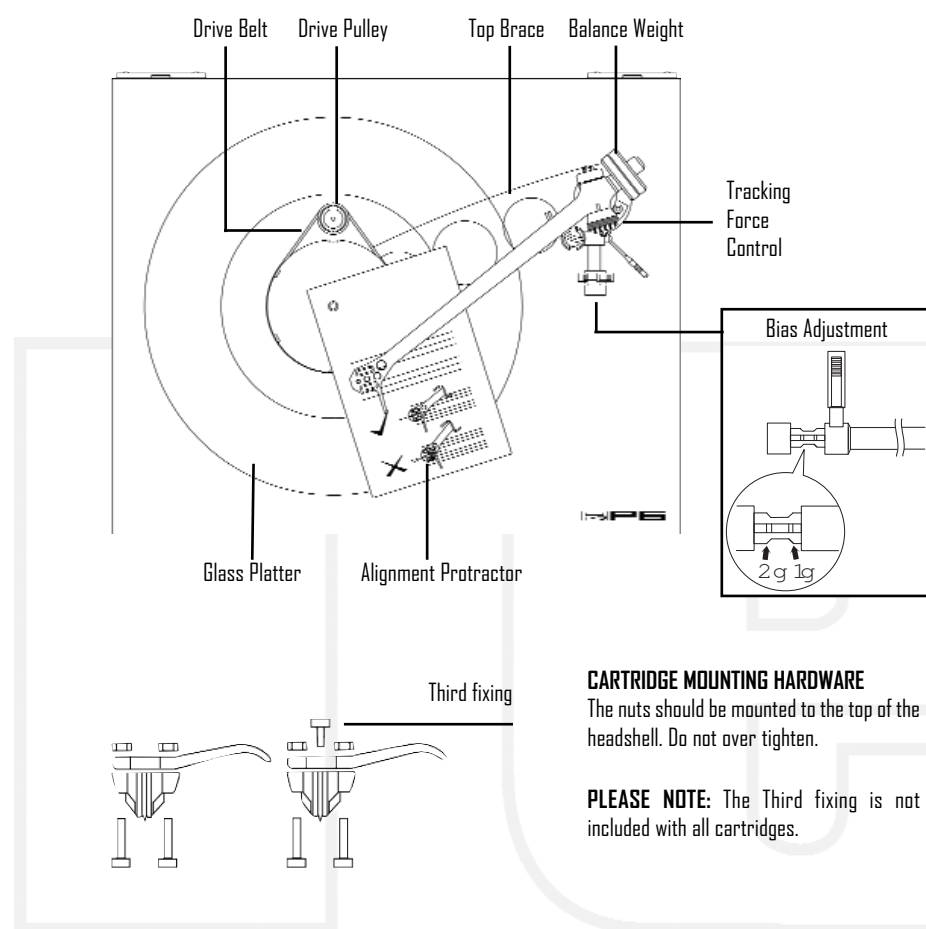

CONNECTION TO THE AMPLIFIER

The tonearm external phono leads must be connected to your amplifier.

Connect as follows : Red right channel / Black left channel. If your amplifier does not have an integrated phono stage you will require an external stage (sold separately).

To keep your **RPG** working perfectly, please ensure that your turntable is returned to a Rega trained dealer for servicing at the recommended interval periods (2000 hours playing time).

POWER SUPPLY

The compact TTPSU uses a high stability crystal locked low distortion sine wave generator. This, along with an efficient drive amplifier fed from a stabilised DC power supply, generates a 24V AC balanced signal of less than 0.1% distortion, which is completely un-affected by any changes in the mains/line voltage and conditions. This then drives the improved Rega anti-vibration circuit, which is situated beneath the turntable.

The speed change is achieved by changing the frequency of the drive voltage; this is because the speed of the platter and motor is directly proportional to the motor drive frequency. A relay switches in the required phase compensation & anti vibration circuit to eradicate motor vibration to a minimum at both speeds.

The TT PSU incorporates resettable fuses in the driver amplifier to protect it from over current faults, which will cause the turntable to run erratically or not at all. If in the rare circumstance these are activated, they are reset by turning off the TTPSU by the front panel for approximately 10 seconds. If the fault should persist consult your dealer.

TTPSU

The tips we give here will help to give you maximum musical enjoyment and ease of use for many years.

Connect the turntable power interconnect between the **TTPSU** and the turntable.

Make sure the **PSI** mains transformer is plugged in and connected to the 24v AC input terminal in the back of the **TTPSU**. Switch the mains power on.

Push the power button on the front panel to turn the **TTPSU** on - When the power supply is switched on, the Rega logo will illuminate RED. This indicates that 33 rpm is selected. To deactivate 33 rpm press the 33/45 button, this will turn the Rega logo to GREEN and will select 45 rpm.

To deactivate 45 rpm press the button again and the Rega logo will return to RED, re-selecting 33 rpm. Please see front panel illustration on page 8.

To minimise the risk of hum pick up by the cartridge, the power supply should be situated as far from the turntable as the interconnect cable will allow.

PLEASE NOTE: When using the TTPSU always leave the belt in the top position as illustrated. There is no need to move the belt position on your RPS.

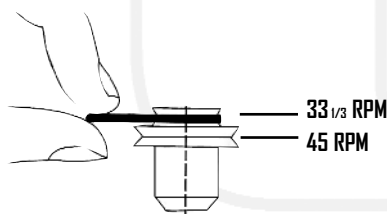

FRONT PANEL CONTROLS

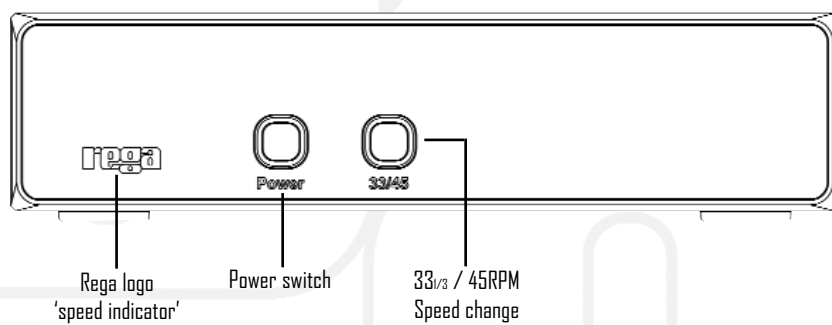

REAR PANEL CONNECTIONS

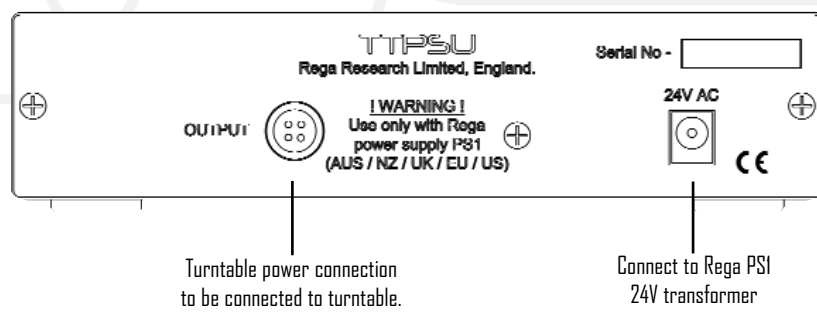

TRANSPORTING YOUR RPB

Should you need to transport your **RPB**, to avoid any possible transit damage, the following recommendations must be followed.

Remove tonearm balance weight and secure the arm in its rest with tape or covered wire. This will ensure no sudden or violent movement is transmitted to the delicate bearings.

Remove platter. When removing, hold down the hub centre at the same time as lifting the platter on each side.

NEVER place your **RPB** upside-down or on its side. This would allow oil in the hub/bearing assembly to leak and cause speed and or wear problems.

If you have to ship your turntable or use a carrier, save and use ALL of the original packaging.

CARE OF YOUR TURNTABLE

Mount the turntable on a rigid, level surface. Avoid mounting on hollow or heavy cabinets or anything mounted on a flexible wooden floor. The Rega turntable support is the ideal solution.

Keeping the lid closed while playing records will prevent dust falling on to the record surface and should make cleaning unnecessary. Depending on the room environment and ambient temperature, playing with the lid open may offer sonic improvements. You can experiment to optimise the performance best suited to your room.

Do not use any record cleaner that works while the record is playing or any cleaners that use water or solvents. If you keep your records stored in their sleeves, avoid touching the playing surfaces and keep all water and fluids away, cleaning should not be necessary. Do not worry about visible dust on the record surface, this is brushed aside by the stylus during play. Dust collected on the stylus can be easily blown away. In general, record cleaning is overdone and one should not believe all the claims made by record cleaner manufacturers.

It is recommended to leave the turntable running during a record playing session. Switch on before the session and only switch off after you have finished.

Do not lift the centre hub out from the main bearing. The bearing is factory assembled with a film of special thick lubricant. If the centre hub is removed this film may be disturbed and the accuracy of the turntable could be affected.

The arm earth (or ground) is automatically connected through the arm cable screening. No other earth method should be necessary.

Do not use any polish on the turntable or lid. To clean, wipe gently with a soft cotton duster (slightly damp only if required).

Rega turntables are designed to optimise performance for music reproduction and therefore no compromises have been made to give quick start times. The normal time taken for full speed to be reached is between 2 and 5 seconds.

As you would expect there is a 24V AC plus a 20V DC signal present on the pins of the plug - if these are shorted it will cause damage to the power unit.

Warning: Any attempt to repair or modify the turntable or tonearm by persons other than Rega approved personnel may invalidate the guarantee. Should you experience any problem with your turntable please contact your Rega dealer.

OWNERS LOG

(1)
Owner.....
Date.....
Where Purchased.....

(2)
Owner.....
Date.....
Where Purchased.....

(3)
Owner.....
Date.....
Where Purchased.....

(4)
Owner.....
Date.....
Where Purchased.....

(5)
Owner.....
Date.....
Where Purchased.....