

NIAGARA 1200

Low-Z Power | Noise-Dissipation System



Owner's Manual

EN Instructions in English are available at the link below.

ES Las instrucciones de instalación en el español se encuentran disponibles en el enlace que se indica a continuación.

FR Les instructions d'installation en français sont disponibles au lien suivant.

ZH 安裝說明請詳見下列網址連結。

JA 日本語 のインストールガイドは下記リンク先でご覧いただけます。

 www.audioquest.com/niagara1200/manual

Table of Contents

Niagara 1200 Features	1
Installation	5
Connection to Audio/Video Components	7
Suggested AC Connections	10
Operation and Continuous Use	12
Specifications	14
Troubleshooting Guide	16
Warranty	20

Niagara 1200 Features

- **Ground Noise-Dissipation System:** AQ's patented technology vastly reduces ground-borne noise without compromising safety or creating low-level ground loops.
- **Linear Noise-Dissipation Technology:** Ensures the most consistent and widest bandwidth noise dissipation possible, without the inconsistent results that typify minimalist, multi-node resonant peaking found in many AC power conditioners.
- **Low-Z AC Power Inlets and Outlets:** These inlets and outlets not only feature the superior grip and lower resistance of beryllium copper, but they also include a heavy Hanging-Silver plating to ensure the lowest impedance at radio frequencies, enabling superior noise dissipation.
- **Non-Sacrificial Surge Suppression:** Will accept multiple transient power surges and spikes up to 6000V or 3000A (the maximum that can make it through a home or office electrical panel). Damage from electrical storms or power-line interruptions is virtually impossible. Set it and forget it.

Introduction

The science of AC power is not simple; it demands focus, and the devil is in the details. In fact, the mammoth increase in airborne and AC-line-transmitted radio signals, combined with overtaxed utility lines and the ever-increasing demands from high-definition audio/video components, has rendered our utilities' AC power an antiquated technology.

Where Alternating Current (AC) is concerned, we're relying on a century-old technology created for incandescent lights and electric motors—technology that was certainly never meant to power the sophisticated analog and digital circuits used in premium audio/video systems. To properly accommodate the promise of today's ever-increasing bandwidth and dynamic range, we must achieve extraordinarily low noise across a wide range of frequencies.

Further, today's power amplifiers and receivers are being taxed for instantaneous peak-current demand, even when they're driven at modest volumes. Although we have seen a substantial increase in both dynamics and bass content from our audio software, the loudspeakers we employ to reproduce them are no more efficient than they were two to four decades ago. This places great demands on an amplifier's power supply, as well as the source AC power supplying it.

Our systems' sensitive components need better alternating current—a fact that has resulted in a host of AC power conditioning, isolation transformers, regeneration amplifiers, and battery back-up system topologies. Through differential sample tests and spectrum analysis, it can be proven that up to a third of a high-resolution (low-level) audio signal can be lost, masked, or highly distorted by the vast levels of noise riding along the AC power lines that feed our components. This noise couples into the signal circuitry as current noise and through AC ground, permanently distorting and/or masking the source signal.

All sincere attempts to solve this problem must be applauded since once the audio/video signal is gone, it's gone forever...

For AudioQuest, honoring the source is never a matter of simply using premium

“audiophile-grade parts” or relying on a proprietary technology—common approaches used within the audiophile market. For years, we have all been witness to the same, seemingly endless audiophile debates: Valves versus transistors. Analog versus digital. Can cables really make a difference? The debates go on and on. While we, too, can brag about our many unique technologies, we realize that true audio/video optimization is never a matter of any one secret or exotic circuit. When it comes to noise dissipation for AC power, many approaches can yield meaningful results. However, they may also impart ringing, current compression, and non-linear distortions that are worse than the disease. The Niagara 1200 uses our patented AC Ground Noise-Dissipation System, coupled to a sophisticated, directionally optimized, wide bandwidth-linearized noise-dissipation circuit.

Though it’s easy to boast, it’s quite another thing to create a solution that is consistent, holistic, functional, and that honors verifiable science. It’s not enough to reduce AC line noise and its associated distortions at just one octave, thus leaving vulnerable the adjacent octaves and octave partials to noise, resonant peaking, or insufficient noise reduction. *Consistency* is key. We should never accept superior resolution in one octave, only to suffer from masking effects a half-octave away and ringing artifacts two octaves from there. This is the principal criterion for AudioQuest’s Low-Z Power Noise-Dissipation System.

The Niagara 1200 represents over 20 years of exhaustive research and proven AC power products designed for audiophiles, broadcast engineers, and professional audio applications. Every conceivable detail has been addressed: In the Niagara 1200, you’ll find optimized radio-frequency lead directionality; run-in capacitor forming technologies developed by Jet Propulsion Laboratories and NASA; and AC inlet and

outlet contacts with heavy silver plating over extreme-purity copper and beryllium copper, assuring a tight grip and high system performance.

A great system is built from a solid foundation, and that foundation starts with power. With an AudioQuest Niagara 1200, you'll experience for the first time the clarity, dimensionality, frequency extension, dynamic contrast, and grip your system has always been capable of delivering—if only the power had been right!

We welcome you to experience the Niagara 1200 and hear firsthand the remarkable results of highly optimized power management: startlingly deep silences, stunning dynamic freedom, outstanding retrieval of ambience cues, and gorgeous delineation of instruments and musicians in space. Once you've experienced it, it may seem so elegant, so logical, and so *fundamental* that you find yourself wondering why it hadn't been done before.

For a comprehensive discussion on AC power technology, including everything that makes AudioQuest's Niagara a more effective AC power solution, please download our "Power Demystified" whitepaper at

<https://www.audioquest.com/content/aq/pdf/Power-Demystified-whitepaper-8-23-18.zip>

—Garth Powell, Director of Power Products, Engineering, AudioQuest

Installation

Unpacking

Before unpacking your Niagara 1200, inspect the carton for any obvious damage to the boxes and internal protective materials. If internal damage is likely, contact the carrier who delivered the unit. If shipping damage is evident on the product, then please contact your shipping carrier. Please save all shipping and packing materials. Should you move or otherwise need to transport your Niagara 1200, these packing materials will ensure the safest transportation.

The corrugated box should contain the Niagara 1200 (120V North American Edison AC Outlets), two foam inserts, owner's manual, chassis polishing cloth, and warranty registration card. Registration is recommended. In the event that your original ownership documents are lost, your registration can be used to establish whether the unit is within the warranty period.

Safety Information | Warnings

Before operating the Niagara 1200, please read and observe all safety and operating instructions. Retain these instructions for future reference.

- Do not disassemble or in any way modify the Niagara 1200. There are no user-serviceable parts inside.
- Keep away from moisture and avoid excessive humidity.
- Do not allow liquids or foreign objects to enter the unit.

Servicing | Return to AudioQuest

Servicing of the Niagara 1200 must be performed by AudioQuest, and is only required when:

- The Niagara 1200 has been exposed to rain, flooding, or extreme moisture.
- The Niagara 1200 does not appear to operate normally. (See “Trouble-Shooting Guide.”)
- The Niagara 1200 has been dropped and sustained considerable physical damage.

If sending the Niagara 1200 to AudioQuest for servicing (or shipping it for any reason), please use the factory approved packaging materials. If you have lost any of these (corrugated carton, foam inserts, one poly bag), please contact AudioQuest for replacements or advice. We will provide replacement packaging materials for a nominal charge; shipping costs will be paid by the individual or company requesting the packaging material. Please do not rely on other methods of packaging, including those provided or suggested by packaging/mailling stores. These methods and materials could seriously damage the product, as well as its finish. Even the loss of the polybag is enough to permanently damage the finish during transport. If you have lost the original packaging material, please request replacement materials from AudioQuest or consult us for appropriate options.

Power Source

Ideally, the power source to which the Niagara 1200 is connected should be adequate for use at 120V single-phase nominal voltage, 15 amps (current capacity RMS). However, the Niagara 1200 will operate very well with a 20-amp service outlet.

For proper operation, the Niagara 1200 requires a safety ground (supplied via the power utility AC wall outlet).

Placement

The Niagara 1200 is manufactured with four rubber feet for safe, secure placement on any table, cabinet, shelf, or floor. It can also be safely mounted on its edge or side (for front edge mounting, we have provided four adhesive rubber bumpers to protect the chassis finish). The Niagara 1200's design obviates the need for compliant or high-Q isolation feet. Although many audio/video products benefit greatly from these devices, the Niagara 1200 does not. However, we do not insist they are not to be used either. Let your ear be your guide.

Placement or proximity to other components is not critical, and, under standard use, the Niagara 1200 does not produce any heat.

Connection to Audio/Video Components

AC Cable Routing

Once the Niagara 1200 is placed, an appropriate 15-amp-rated AC cord must be connected to the AC inlet (IEC-C14) connector. The AC cord must have an IEC-C13 female end connector and a grounded male 120VAC Edison/NEMA plug for use in North America or Taiwan. We highly endorse the use of any AudioQuest 15-amp-rated (or high-current) AC cord, as the patented Ground Noise-Dissipation relies on our directionally controlled conductors for best performance. However, the Niagara 1200 will function properly with any appropriate AC cord that meets the aforementioned requirements.

Whenever possible, it is best to keep at least three inches (approximately 7cm) between AC cables and any signal cable. When this is not possible in a practical layout of system cabling, crossing the AC cables to signal cables at 90 degrees is best to minimize induced noise.

High-Current Power Bank

The two High-Current Power Banks were designed to enhance the performance of power amplifiers, powered subwoofers, and powered receivers via the Niagara 1200's low-impedance, differential-filter circuitry. This, coupled with the patented Ground Noise-Dissipation System, ensures maximum performance from any power amplifier without the typical performance-limiting effects of current compression found in many typical "power conditioners."

The other five AC outlet banks are inappropriate for high-current power amplifiers. They have instead been optimized for line-level audio preamplifiers, DACs, universal players, turntables, digital devices, and video products that utilize constant current voltage amplifier circuits. These circuits never suffer from current compression, but their lower input level and higher gain require a more robust means of noise dissipation. This is key to the Niagara 1200's discrete AC power banks (the top three, the two below those, and the two high-current banks), in that not every circuit is treated the same, but rather isolated bank by bank for best performance.

Linear Noise-Dissipation System

There are five outlets that utilize this technology within the Niagara 1200. Though it would be simple to recommend putting the digital or video components into the upper three outlets and the line-level audio components and turntable into the two banks below them, the quest for optimal performance is more complex. This scenario will work, and likely work well, but a certain amount of experimentation is best given the fact that no filter or screen can eliminate 100% of all noise. The size of many of these RF-induced waveforms is as small as the edge of a piece of paper, and the interactions are complex. So long as the power amplifier, powered subwoofer, or powered receiver are in the two AC outlets labeled “High Current,” and the other components are in some combination of the five outlets above, you should experience exemplary performance. The outlet that sounds best (yielding the greatest resolution) is the best one for *your* system!

Suggested AC Connections

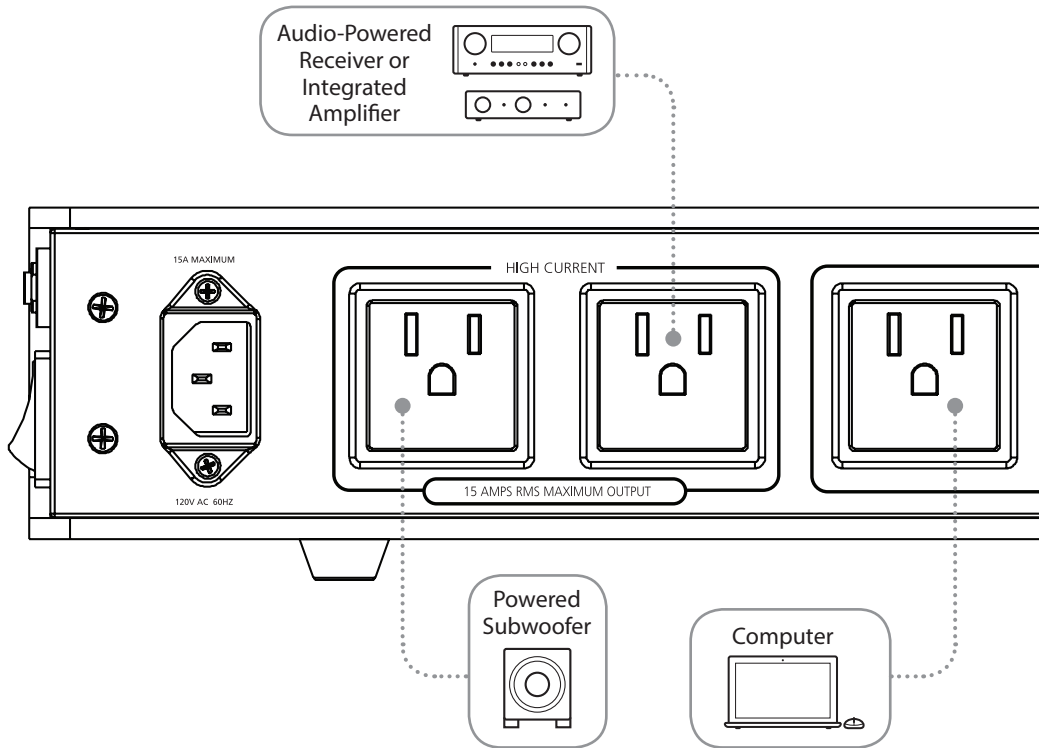

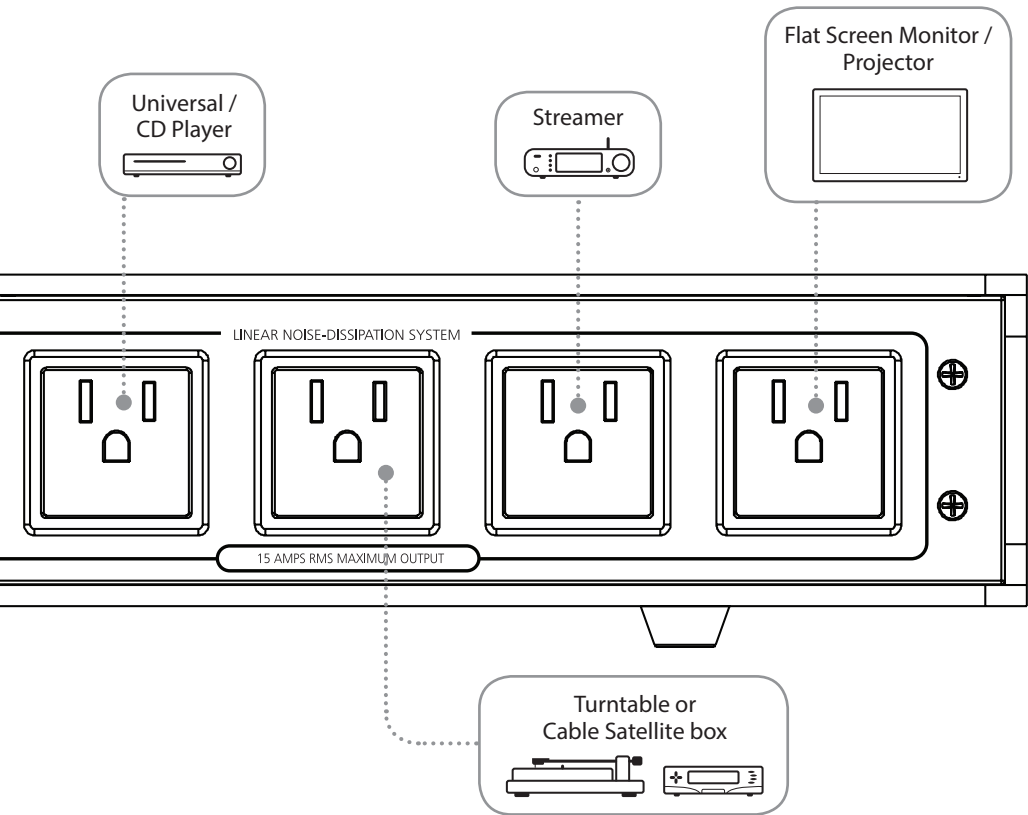

Operation and Continuous Use

Power Switch | Circuit Breaker and LED Power Indicator

Once the AC cords are properly connected to the AC source tap, and the components are connected to the appropriate outlet banks, it is safe to energize the Niagara 1200. On the left side of the Niagara 1200's chassis, there is a black rocker switch. Firmly press the rocker switch so that its upper portion is flush with the end-cap or panel. This position is marked with the number "1." Typically within a second, you should hear an audible "clack" sound from the relay within the Niagara 1200. At the same time, the adjacent LED power indicator will glow blue, signifying that the unit is operational. (If this does not occur, see the "Trouble-Shooting Guide" in this manual.)

Extreme Voltage Indicator

One portion of the Niagara 1200's non-sacrificial surge protection is dedicated to a fast-acting extreme voltage shutdown circuit. If more than 140VAC is present on the incoming AC line for more than a quarter of a second, the circuit will instantly open a high-current relay that will disengage the AC power from all of the Niagara 1200's AC outlets, activating the red LED "Extreme Voltage" warning indicator. Once the event has passed, or the building wiring fault has been corrected, the circuit will automatically re-engage.

Break-in Time | Continuous Use

The Niagara 1200 is made of a variety of passive and active components. Though every attempt has been made to reduce the necessity of so-called “break-in,” “burn-in,” or “run-in” time—including high-power run-in of every critical capacitor in the Linear Noise-Dissipation Circuits—the Niagara 1200 will benefit from continuous use, just like any other audio/video component. This is not to say that you will be made to “suffer” through weeks or months of intolerable performance until that “magic day” when the parts are fully formed and ready. On the contrary, the Niagara 1200 will perform very well from the first moment you use it. It will improve gradually, in small increments, over a period of approximately two weeks. While leaving the Niagara 1200 turned on during this period will aid the process, it is also perfectly acceptable to turn the unit off; doing so will simply increase the time it takes to reach final “break-in.”

The Niagara 1200 has a five-year warranty, but it was designed to last for over two decades. Provided that the Niagara 1200 is used inside a home, store, studio, or office with a reasonable climate (45 degrees to 100 degrees Fahrenheit, with less than 20% humidity), it can be left on continuously; there are no parts that will wear out.

Specifications

Surge Suppression:	Non-sacrificial (nothing to damage with repeated 6000V/3000A input surge tests, which is the maximum that can survive through a building's AC electrical panel).
Extreme Voltage Shutdown Voltage:	140VAC (will activate the main high-current relay to open within less than 0.25 second; automatically resets once the incoming power is within a safe range).
Transverse-Mode Noise Dissipation:	In excess of 24dB from 20kHz to 1GHz, linearized for dynamic (rising) line impedance with frequency (source) and 10- to 50-ohm load, <i>system current dependent</i> .
Input Current Maximum Capacity:	15 amps RMS (total).
Linear Filtering, High Current, and Ground Noise-Dissipation AC Outlet Banks:	3 (Group one consists of the 3 isolated Linear Filtered AC outlets (on the far right when facing the rear panel). The 2 that follow are another bank of isolated Linear Filtered AC outlets), and at the far left are the 2 isolated High-Current outlets.

Number of AC Outlets:	7 (2 High Current/Ground Noise Dissipated; 5 Ultra-Linear Filtered/Ground Noise Dissipated).
Power Consumption:	Typically, less than 5W at 120VAC input.
Dimensions:	Width 19.61" Height 3.41" Depth 7.52"
Weight:	15.10 lbs.

Troubleshooting Guide

At AudioQuest, we always appreciate hearing from you. However, if you have questions, problems, or suspect that your Niagara 1200 requires service, please start here.

There is no power to any of the AC outlets.

When the Niagara 1200's front-panel LED power indicator glows blue, the unit is operational. If the Power On indicator is not lit, consider the following:

- Is the upper portion of the bottom end-cap rocker switch fully flush with the chassis and in the "1" position?
- Is the input AC cord fully inserted into the Niagara 1200's AC inlet?
- Is the input AC cord properly plugged into the wall AC service outlet?
- Is the wall's AC outlet functioning properly?

Plug into the outlet another component, product, or lamp to verify that power is present and that the electrical panel's circuit breaker has not tripped. If there are only one or two AC outlets that have no output power, a component may be malfunctioning. Verify the AC output with a known simple device such as a lamp.

- Is the 15-amp circuit breaker tripped?

The bottom end-cap or panel has one 15-amp circuit breaker with a reset button. Simply push the button to reset the breaker. It is quite unlikely this would occur, but if a large appliance or a defective component were to experience a short circuit, this breaker device will activate, thus saving itself and the connected equipment.

If you discover that one or multiple products activate the circuit breaker, check the current consumption rating of that/those products. (Typically, this information can be found on the last page of the component's owner's manual; it should be listed as the power consumption at 120VAC.) The current specification will typically be in watts. Know that 15 amps at 120VAC equals 1800 watts. (You will want to be at least slightly under that number.)

There is no power to any of the AC outlets and the red front-panel Extreme Voltage indicator is lit.

This indicates that either there is more than 140VAC (+/-3V) present on the wall's AC service outlet, or the Niagara 1200's protection circuit is mis-calibrated. The latter is quite rare. (This circuit is adjustable, but it's tested and retested before it leaves the factory, and it's designed so that shipping will not affect it.) Use an AC voltage meter to determine if your outlet has too much voltage to be safe for operation, or if there is a wiring fault that is causing this to occur.

Once the power is brought into a safe range for operation (90VAC to 137 VAC), the Niagara 1200's protection circuit will automatically switch to operational mode and the blue power indicator will light.

My power amplifiers sound muddy, compressed, or weak.

Be sure that the power amplifier, powered subwoofer, or powered receiver is plugged into one of the High-Current AC outlets. If any power amplifier is plugged into any of the five Linear Filtered Power outlets, the connected power amplifier *may* (in certain cases), be subject to current compression.

I have two powered loudspeakers or an additional powered subwoofer. Can I use one of the Linear Filtered outlets?

The circuit utilized for these five AC outlets is in part a series filter, so by definition it will raise the AC impedance *slightly* (although the circuit utilized in the Niagara 1200 can sustain an extraordinary **50 amps peak** before soft clipping occurs). Like many system interactions, it's impossible to simply intuit whether current compression is a concern; it will vary by amplifier. To be sure, you must listen to the results. In many situations, powering an additional amplifier or powered speaker from one or more of the five Linear Filtered Power AC outlets may work very well.

My home or grounds were hit by lightning. The Niagara 1200 seems to be functioning properly. Should it be sent in for inspection or service?

If you see or smell smoke coming from the unit, it needs service. Otherwise, if it functions after such an event (which is very likely), there is nothing that would be compromised or damaged. If it fails after such an event, it will fail totally. However, it's unlikely that this would occur. The circuit is designed to easily handle any voltage or current surge that could possibly make it past an electrical panel. The force required to damage the Niagara 1200 via a power surge would melt the panel and burn the building (in which case, the Niagara 1200 is the least of your worries).

How do I clean the chassis and/or the electrical contacts?

The Niagara 1200's anodized cover and painted chassis can be cleaned with AudioQuest CleanScreen or a modest misting of household window cleaners. For removing fluid residue, please use soft cotton or wool toweling. Only use liquid cleaner when oil or

grime is beyond a polishing cloth's capacity to thoroughly clean. Never use alcohol or solvent-based cleaners. They can damage the surfaces and silk-screening material.

The AC inlet, outlet posts, and grips are all generously plated with silver. There is no need to clean these if they are not exposed to foreign substances such as grease and dirt. Silver oxide is a superior conductor to silver itself. If cleaning is required, Isopropyl alcohol (preferably 99% purity) on a cotton swab is best for the inlet tabs. Some manufacturers provide specialized cleaners for the AC output surfaces. Again, however, cleaning these surfaces will most likely be unnecessary.

Note: A pipe cleaner or cleaning swab with a wood stick and compact wool tip (available from an electronics supply house) will be superior to household swabs. When working in a small area such as an AC outlet, this is critical. Loose strands of cotton may damage the AC outlet. Damage to an AC inlet or outlet due to cleaning is not covered under your warranty. If you damage an inlet or outlet in an attempt to clean it, you will be charged for the repair and you will be responsible for all shipping costs.

Warranty

The Quest Group, DBA: AudioQuest, warrants to the original purchaser of this AudioQuest Niagara 1200, will be free from defects in material and workmanship for a period of one year. The purchaser of the product is allowed 30 days from the date of purchase to complete the warranty registration by mail or on-line at the AudioQuest website. If the purchaser completes the aforementioned registration, the warranty period will be increased to five years from the date of purchase.

If the product does not conform to this Limited Warranty during the warranty period (as herein above specified), purchaser shall notify AudioQuest in writing (or e-mail), of the claimed defects. If the defects are of such type and nature as to be covered by this warranty, AudioQuest shall authorize the purchaser to return the product to the AudioQuest factory (2621 White Road, Irvine, California, 92614 USA). Warranty claims should be accompanied by a copy of the original purchase invoice showing the purchase date; this is not necessary if the Warranty Registration was completed either by mailing in the completed warranty card or by registering online at the AudioQuest website. Shipping charges to the AudioQuest factory (Irvine, California, USA) must be prepaid by the purchaser of the product. AudioQuest shall, at its own expense, furnish a replacement product or, at AudioQuest's option, repair the defective product. Return shipping charges back to the purchaser will be paid by AudioQuest.

All warranties contained herein are null and void if: the AudioQuest AC power product (Noise-Dissipation System) has been opened, improperly installed, altered in any way, or tampered with. AudioQuest is not responsible for any connected equipment or any claims of damage to connected equipment due to the occurrence of an AC power surge,

spike, or over-voltage event, unless AudioQuest determines after thorough inspection and testing by AudioQuest (with product shipped to AudioQuest USA at the owner's expense), that the protection circuitry was in whole or in part improperly functioning. AudioQuest is not responsible for any connected equipment that is damaged due to external signal lines (non-AC power lines), that carry an electrical storm or signal wiring fault surge or spike (such as Ethernet, cable, and satellite connections). All AudioQuest AC power products (Noise-Dissipation Systems), must be plugged directly into a properly wired AC power line with a protective ground.

AudioQuest AC power products (Noise-Dissipation Systems) cannot be "daisy-chained" together in serial fashion with other AC power strips, UPS devices, other AC surge protectors, AC power conditioners, three-to-two prong adapters, or AC extension cords. Any such installation voids the warranty. The AudioQuest warranty only protects against damage to properly connected equipment or AC cables where AudioQuest has determined, at its sole discretion, that the damage resulted from an AudioQuest power product (Noise-Dissipation System) circuit or protection circuit malfunction and does not protect against acts of God (other than lightning, such as flood or earthquake), war, terrorism, vandalism, theft, normal use wear and tear, erosion, depletion, obsolescence, abuse, damage due to low-voltage disturbances (i.e., brownouts or sags), or system equipment modification or alteration. Do not use this product in any way with a generator, heater, sump pump, water-related devices, life-support devices, medical devices, automobile, motorcycle, or golf-cart battery charger. To be used indoors only and in dry areas. All warranties contained herein are null and void if used in any way with any of the aforementioned devices.

THE FOREGOING IS IN LIEU OF ALL OTHER WARRANTIES, EXPRESS OR IMPLIED, INCLUDING BUT NOT LIMITED TO THE IMPLIED WARRANTIES OF MERCHANTABILITY AND FITNESS FOR A PARTICULAR PURPOSE. AudioQuest does not warrant against damages or defects arising out of improper or abnormal use or handling of the product, against defects or damages arising from improper installation, against defects in products or components not manufactured by AudioQuest, or against damages resulting from such non-AudioQuest made products or components. This warranty shall be cancelled by AudioQuest at its sole discretion if the product is modified in any way without written authorization from AudioQuest. This warranty also does not apply to products upon which repairs have been affected or attempted by persons other than pursuant to written authorized by AudioQuest.

THIS WARRANTY IS EXCLUSIVE. The sole and exclusive obligation of AudioQuest shall be to repair or replace the defective product in the manner and for the period provided above. AudioQuest shall not have any other obligation with respect to this product or any part thereof, whether based on contract, tort, strict liability, or otherwise. Under no circumstances, whether based on this Limited Warranty or otherwise, shall AudioQuest be liable for incidental, special, or consequential damages. AudioQuest employees or representatives' ORAL OR WRITTEN STATEMENTS DO NOT CONSTITUTE WARRANTIES, shall not be relied upon by purchaser, and are not a part of the contract for sale or this limited warranty. This Limited Warranty states the entire obligations of AudioQuest with respect to the product. If any part of this Limited Warranty is determined to be void or illegal, the remainder shall remain in full force and effect.

Warranty claims should be accompanied by a copy of the original purchase invoice showing the date of purchase. (If a Warranty Registration Card was mailed in at the time of purchase or if the product was registered online, this is not necessary.) Before returning any equipment for repair, please be sure it is adequately packed and cushioned in either the original or a new AudioQuest factory-supplied polybag, foam insert pair, and dual carton set to protect against damage in shipment, and that it is insured.

©2019 AudioQuest 2621 White Road, Irvine CA 92614 USA
info@audioquest.com | www.audioquest.com

audioquest[®]

March 2019