



# T1

## New Generation Audiophile Entry Level Turntable

MSRP 279 € (incl. VAT)

- Belt-driven
- Anti-resonant sub-platter design
- Heavy 8mm, zero-resonance blasted-glass platter
- Precision CNC'd heavy full chassis:  
    NO hollow spaces, NO plastic
- Ortofon OM 5E moving magnet pickup
- 8,6" highly precise and light aluminium tonearm
- Low friction, vibration free tonearm bearing
- One-piece tonearm design with integrated headshell
- Super shielded, semi-symmetrical, low-capacitance phono cables - purpose designed by Pro-Ject
- Vibration absorbing feet
- Elegant dustcover with adjustable hinges
- Available in High-Gloss Black, Satin White and Walnut
- Hand-made in Europe

Walnut finish: 

Satin White: 

High-Gloss Black: 

**Speed:** 33,45 (manual speed change)

**Principle:** Belt drive

**Speed variance:** 33: 0.7% 45: 0.6%

**Wow & Flutter:** 33: 0.25% 45: 0.23%

**Platter:** Heavy 8mm, blasted-glass platter with felt mat

**Main bearing:** Stainless steel/brass

**Signal to noise:** 65dB

**Tonearm:** 8.6" aluminium

**Effective arm length:** 218.5 mm

**Overhang:** 22.0 mm

**Effective tonearm mass:** 8.0 g

**Counterweight for mass:** 5 - 10g (pre-mounted)

**Tracking force range:** 0 - 50mN (17.5 mN pre-adjusted)

**Included accessories:** dustcover, feltmat

**Built-in Power Supply:** 230V 50Hz (US: 110V 60Hz)

**Power consumption:** 3 Watt max

**Dimensions:** 415x100x335 mm (WxHxD)

**Weight:** 3.8 kg net

## Pro-Ject T1: A New Generation of Turntable

The T1 from Pro-Ject Audio Systems is the first T-Line turntable, aiming to deliver true high-fidelity sound on a limited budget. Boasting premium materials, stylish aesthetics and a rich, lively sound, the extensive development process has ensured that there has been no compromise in the sound performance when achieving such an affordable price.

The stylish CNC-machined plinth, available in High Gloss Black, Satin White or Walnut finish, features no plastic parts and is carefully manufactured to ensure there are no hollow spaces inside, therefore avoiding unwanted vibrations within the chassis.



Superb build-quality, stylish looks and audiophile sound  
Precision CNC'd plinth and heavy zero-resonance glass platter

Carrying this philosophy through the design, the glass platter is also a heavy, zero-resonance design – again avoiding the flaws of plastic or lightweight steel alternatives. Finally, the purpose-chosen turntable feet also do a good job of isolating the T1 from ambient vibrations around your hi-fi system.

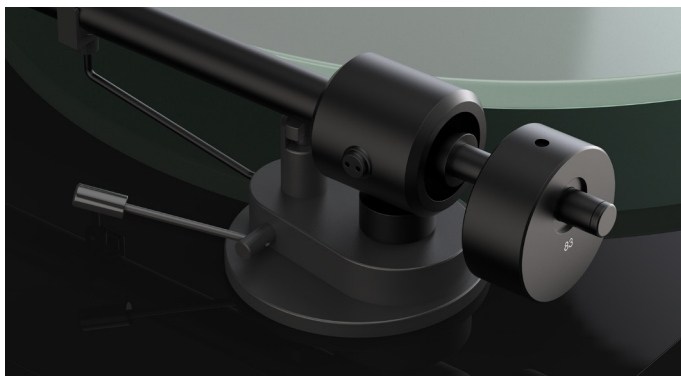

Low-friction bearing  
Fast, clean and precise tracking

## Pushing Audiophile Design to a new Affordable Level

In the T1, the motor drives a belt-system, attached to a newly designed sub-platter, which is mounted into an ultra-precise 0.001mm main bearing with a hardened steel axle and brass bushing – just like our coveted Essential III turntables.



Ultra-precise motor and sub-platter design  
Lowest noise with immaculate speed stability

Alongside the chosen motor system, the T1 is therefore able to ensure a smooth, anti-resonant rotational platform for the tonearm and cartridge to ride across.



One-piece aluminium tonearm  
Robust and stiff construction for pure sound fidelity

The tonearm on the T1 is a new model, based on previous Pro-Ject designs. With its straight, 8.6" effective length and stiff aluminium construction, this one-piece tonearm also features low-friction bearings for absolute accuracy in use. Besides the clean and stylish looks, the integrated headshell won't cause any additional vibrations either, and is a big improvement over other detachable, screwed-on or glued-on headshells!

Supplied with an Ortofon OM 5E Moving Magnet cartridge, featuring an elliptical diamond stylus tip; this is a true hi-fi playback system with no corners cut.

The T1 is then finished with super shielded, semi-symmetrical, low-capacitance phono cables, purpose-designed by Pro-Ject – not off-the shelf RCA cables. There is also a dust cover for extra protection and a felt mat to protect your records.

The T1 is a new affordable marvel. Still made in Europe by a turntable factory with decades of experience, it is a true hi-fi turntable that looks and sounds sublime.



High-quality Ortofon OM 5E Moving Magnet cartridge with elliptical stylus tip



High-gloss Black



Walnut



Satin White



**No corners cut!**  
**Audiophile engineering. No plastic. More sound.**