

Operation

3.0

Gain

Anni benefits from a two-stage (high and low) gain function on the loudspeaker outputs (only) to suit a wide range of partnering speakers. Press the gain button to alternate between low (blue) and high (red) gain modes, allowing 3 seconds to switch between modes.

⚠ When using either of the headphone outputs, Anni is automatically switched to low gain mode. If when inserting headphones Anni was previously set to high gain (red) the gain sphere will show purple, before reverting back to red when the headphones are removed. If low gain (blue) was previously selected, the gain sphere will remain blue and continue to display blue when the headphones are disconnected.

⚠ If using Anni with Qutest, ensure Qutest's output voltage is set no higher than 2 V. The Qutest manual describes how to set output voltage.

Placement

Anni benefits from extensive casework ventilation and a cooling fan for demanding environments. Always ensure Anni is used in a well-ventilated setting, away from direct sunlight and heat sources, and has sufficient space around the unit.

Chord Electronics' Qutest Stand System (available separately) has been designed to perfectly house Anni. Otherwise, care should be taken not to stack other units on Anni.

Support

If you need support, in the first instance, please contact your supplying retailer who will be best placed to assist you. If you need additional help beyond that of your retailer, please visit our support page: chordelectronics.co.uk/get-support

Specifications

Power output	10 W 8 ohms
THD	0.02 %
Signal to noise	-92 dB
Noise floor	-110 dB
Frequency response	5 Hz-60 kHz



Anni Manual

V.1

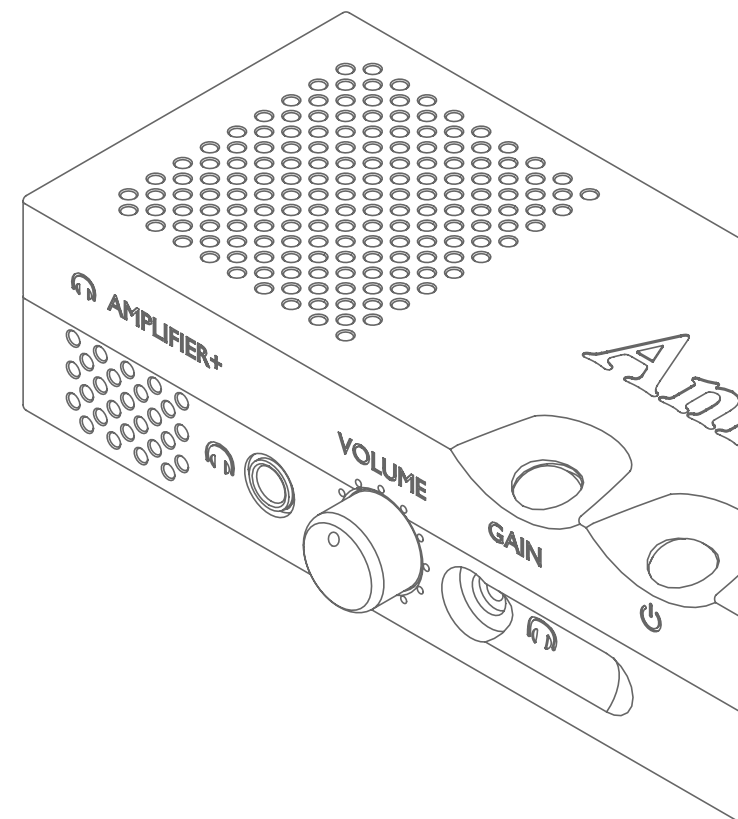

General operation and important information

1.0

Introduction

Anni is a next-generation desktop integrated amplifier that complements the high quality of our multi-award-winning Qutest DAC and Huei phono stage. We took a different approach to the design and created a powerful, desktop device for headphones and desktop loudspeakers that belies its compact dimensions.

Accurately controlled across the entire audio bandwidth with extraordinary low frequency capability, Anni's protection circuitry allows for the delivery of enormous peak current outputs for its size whilst avoiding overdrive; it does this differently to other amplifiers on a half-cycle by half-cycle basis. If the output of the amp is being over-driven, Anni will detect it and collapse the waveform on each over-driven, half-cycle. So not clipping like other amplifiers but instead going from a completely undistorted waveform to one that is missing half-cycles i.e. it becomes heavily distorted suddenly until the level is slightly reduced. Then the music signal will totally recover without any harm occurring to the amplifier or speaker, with the music being once again undistorted.

Connections and controls 2.0

Rear

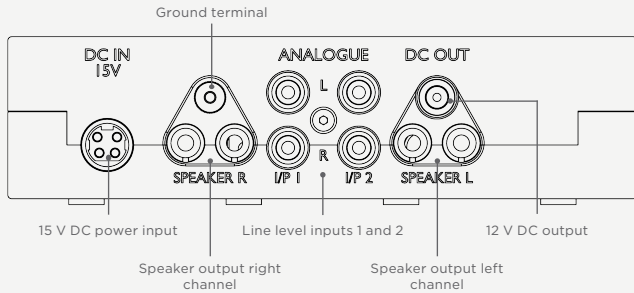

Front

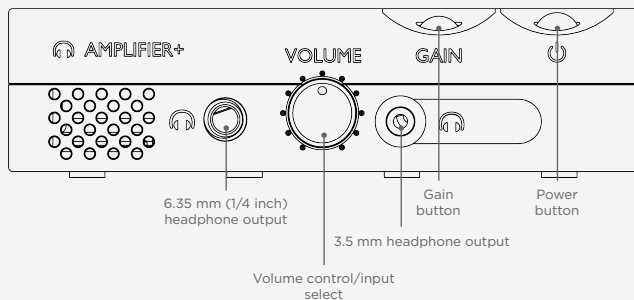

Connections and controls

2.0

Power connection

Anni is supplied with an external power supply and has been designed to be permanently connected to a power source. Connect the included 15 V supply to Anni. If hum occurs, use the ground terminal to connect to an available earth point. Always set the volume to zero before playback and before connecting/removing headphones.

Inputs

2.1

Connect to any line level source component using a standard RCA cable.

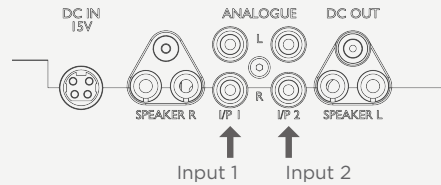

Connecting to loudspeakers

2.2

Connect to the loudspeaker using 4 mm banana-plug-terminated speaker cable, observing polarity.

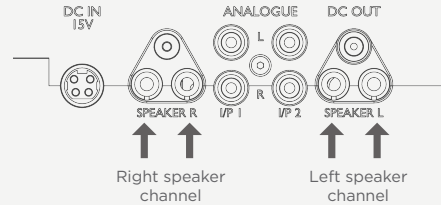

Connecting to headphones

2.3

Using the front two outputs, connect headphones with 6.35 mm (1/4-inch) or 3.5 mm terminations to Anni and the output will automatically be selected. The volume controls both headphone outputs simultaneously: they are not independently controllable.

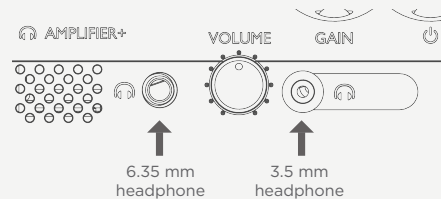

Operation

3.0

Power on/off

3.1

With connections successfully made (as per section 2.0), and volume set to zero, press the power button. The button will display green, before settling on cyan. Pressing the power button again puts the unit in standby; the button will display red.



Note: if either of the headphone outputs are connected, the power button will display green to show the speaker output has been disconnected. If the headphones are then removed, the power button will revert to cyan and the speaker output will become active.

Select an input

3.2

Select input 1 or 2 by pushing the volume knob sequentially. Input 1 is indicated by a blue LED ring, input 2 is red.

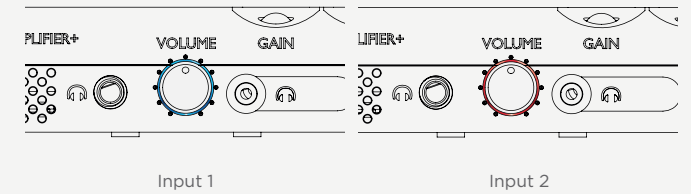

Amplifier operation

3.3

With connections successfully made and with volume set to zero, select the input, press play on the chosen source and adjust Anni's volume accordingly.

Headphone operation

3.4

Anni has both 6.35 mm (1/4 inch) and 3.5 mm headphone outputs, which can be used both individually or simultaneously meaning two can listen. With the volume set to zero, connect to one or both headphone outputs and slowly increase the volume.



Note: if connecting headphones when music is already playing through the loudspeakers, a short delay will be experienced before the headphone output becomes active (to protect the amp). In addition, low gain will be automatically selected. Removing the headphones (with speakers still connected) will revert the output signal back to the speakers.