



# EDGE A

INTEGRATED AMPLIFIER



P.02

EN

P.10

DE

P.18

FR

P.26

ES

P.34

IT

P.42

SV

P.50

RU

P.58

中文

P.66

日本語

# Contents

IMPORTANT SAFETY INFORMATION	3
FRONT PANEL	5
REAR PANEL	6
REMOTE CONTROL	7
BLUETOOTH	8
POWER SYNCING	9
TECHNICAL SPECIFICATION	10
TROUBLESHOOTING	11

First and foremost, thank you for choosing Cambridge Audio.

I'm sure that you're excited to listen to your new acquisition; I hope your expectations will be surpassed and that the pleasure will continue for many years to come.

At Cambridge Audio we are in awe of the way that music can move us. It's something that isn't easy to describe, but you know how wonderful it is.

Personally, listening to a quality system provokes the same reaction every time, it takes hold of me, possesses me and demands that I listen. I can lose myself for hours on a voyage of discovery, playing tracks that I haven't heard in years, and they all sound brand new. It thrills me, I'll be nodding, grinning, tapping and if there's a glass of wine involved, dancing like a fool! It's as exciting as hearing the songs for the first time, but with the added delight of recalling feelings and memories too. It really is a beautiful thing.

And that power is why we developed Edge, the pinnacle of five decades of engineering precision, continuous audio innovation and our lasting love of music. It's the inevitable conclusion to the singular objective that's guided Cambridge Audio from the start; to produce audio equipment that faithfully delivers a pure and natural sound. Nothing added, nothing taken away.

Cambridge Audio was born in 1968, when a promising R&D business established by some talented young technology graduates in Cambridge, England, turned their attention to stereo amplifiers. Britain in the 1960's was an incredibly exciting place to be - a time when British bands began to enjoy unprecedented global success, our studios led the way in recording technology and a small group of enterprising British engineers started to make equipment that would accurately playback these landmark recordings.

50 years on, and all our engineering and design is still carried out in the UK, by our dedicated teams in London and Cambridge. There's a few more of us working here now, and our head-office has relocated to central London; where we proudly continue to deliver world class hi-fi.

Our quest for audio perfection is built on simple principles; minimise the number of components in the signal path and select each component by listening to discover those with the purest sound. We're immensely proud of what we've created, having spared nothing in our efforts for perfection.

But ultimately this is about far more than the equipment and it's even more important than the music, it's about your experience when you listen. We hope that your Edge will transport you to some of the magical moments in your life, reminding you exactly why you fell in love with music in the first place.

Time to sit down, take a breath, and let the music take you away, wherever your heart desires.



**Stuart George**  
MANAGING DIRECTOR, CAMBRIDGE AUDIO

This guide is designed to make installing and using this product as easy as possible. Information in this document has been carefully checked for accuracy at the time of printing; however, Cambridge Audio's policy is one of continuous improvement, therefore design and specifications are subject to change without prior notice.

This document contains proprietary information protected by copyright. All rights are reserved. No part of this manual may be reproduced by any mechanical, electronic or other means, in any form, without prior written permission of the manufacturer. All trademarks and registered trademarks are the property of their respective owners.

© Copyright Cambridge Audio Ltd 2018.

Qualcomm is a trademark of Qualcomm Incorporated, registered in the United States and other countries, used with permission. aptX is a trademark of Qualcomm Technologies International, Ltd., registered in the United States and other countries, used with permission.

Qualcomm aptX is a product of Qualcomm Technologies International, Ltd.

The Bluetooth® word mark and logos are registered trademarks owned by the Bluetooth SIG, Inc. and any use of such marks by Audio Partnership Plc is under license. Other trademarks and trade names are those of their respective owners.

**Make sure you register your Edge unit at:**  
[WWW.CAMBRIDGEAUDIO.COM/REGISTER](http://WWW.CAMBRIDGEAUDIO.COM/REGISTER)

For upcoming news on future products, software updates and exclusive offers.

# Important safety information

For your own safety please read the following important safety instructions carefully before attempting to connect this unit to the mains power supply. They will also enable you to get the best performance from and prolong the life of the unit:

1. Read these instructions.
2. Keep these instructions.
3. Heed all warnings.
4. Follow all instructions.
5. Do not use this apparatus near water.
6. Clean only with a dry cloth.
7. Do not block any ventilation openings. Install in accordance with the manufacturer's instructions.
8. Do not install near any heat sources such as radiators, heat registers, stoves, or other apparatus (including amplifiers) that produce heat.
9. Do not defeat the safety purpose of the polarized or grounding-type plug. A polarized plug has two blades with one wider than the other. A grounding-type plug has two blades and a third grounding prong. The wide blade or the third prong are provided for your safety. If the provided plug does not fit into your outlet, consult an electrician for replacement of the obsolete outlet.
10. Protect the power cord from being walked on or pinched, particularly at plugs, convenience receptacles and the point where they exit from the apparatus.
11. Only use attachments/accessories specified by the manufacturer.
12. Use with only the cart, stand, tripod, bracket, or table specified by the manufacturer, or sold with the apparatus. When a cart is used, use caution when moving the cart/apparatus combination to avoid injury from tip-over.
13. Unplug this apparatus during lightning storms or when unused for long periods of time.



14. Refer all servicing to qualified service personnel. Servicing is required when the apparatus has been damaged in any way, such as the power-supply cord or plug having been damaged, liquid has been spilled or objects have fallen into the apparatus, the apparatus has been exposed to rain or moisture, does not operate normally, or has been dropped.

## WARNING:

- Do not place the unit in an enclosed space; if you wish to place the unit on a shelf, use the top shelf to allow maximum ventilation. Do not put any objects on top of this unit. Do not situate it on a rug or other soft surface and do not obstruct any air inlets or outlet grilles. Do not cover the ventilation grilles with items such as newspapers, tablecloths, curtains, etc.
- To reduce the risk of fire or electric shock, do not expose this apparatus to rain or moisture. This unit must not be used near water or exposed to dripping or splashing water or other liquids. No objects filled with liquid, such as vases, shall be placed on the unit.
- Danger of explosion if battery is incorrectly replaced. Replace only with the same or equivalent type.
- The battery (battery pack or batteries installed) shall not be exposed to excessive heat such as sunshine, fire or the like.
- The unit must be installed in a manner that makes disconnection of the mains plug from the mains socket outlet (or appliance connector from the rear of the unit) possible. Where the mains plug is used as the disconnect device, the disconnect device shall remain readily operable.
- Please refer to the information on the exterior rear panel for electrical and safety information before installing or operating the apparatus.
- Only use the mains cord supplied with this unit.

Use of the apparatus in tropical climates - The equipment shall be used at a maximum 45 degree C ambient temperature.

The unit is of Class 1 construction and must be connected to a mains socket outlet with a protective earthing connection.



The lightning flash with the arrowhead symbol within an equilateral triangle is intended to alert the user to the presence of un-insulated 'dangerous voltage' within the product's enclosure that may be of sufficient magnitude to constitute a risk of electric shock to persons.

Warning: To reduce the risk of electric shock, do not remove cover (or back) as there are no user-serviceable parts inside. Refer servicing to qualified personnel.

The exclamation point within an equilateral triangle is intended to alert the user to the presence of important operating and maintenance instructions in the service literature relevant to this appliance.

## VENTILATION

**Important!** The unit will become hot when in use. Do not stack multiple units on top of each other.

Ensure that small objects do not fall through any ventilation grille. If this happens, switch off immediately, disconnect from the mains supply and contact your dealer for advice.

## POSITIONING

Choose the installation location carefully. Avoid placing it in direct sunlight or close to a source of heat. No naked flame sources, such as lighted candles, should be placed on the unit. Also avoid locations subject to vibration and excessive dust, cold or moisture. The unit can be used in a moderate climate.

This unit must be installed on a sturdy, level surface. Do not place in a sealed area such as a bookcase or in a cabinet. Do not place the unit on an unstable surface or shelf. The unit may fall, causing serious injury to a child or adult as well as serious damage to the product. Do not place other equipment on top of the unit.

Due to stray magnetic fields, turntables or CRT TVs should not be located nearby due to possible interference.

Electronic audio components have a running in period of around a week (if used several hours per day). This will allow the new components to settle down and the sonic properties will improve over this time.

## POWER SOURCES

The unit should be operated only from the type of power source indicated on the marking label. If you are not sure of the type of power-supply to your home, consult your product dealer or local power company.

If you do not intend to use this unit for a long period of time, unplug it from the mains socket.

## OVERLOADING

Do not overload wall outlets or extension cords as this can result in a risk of fire or electric shock. Overloaded AC outlets, extension cords, frayed power cords, damaged or cracked wire insulation and broken plugs are dangerous. They may result in a shock or fire hazard.

Be sure to insert each power cord securely. To prevent hum and noise, do not bundle the interconnect leads with the power cord or speaker leads.

## CLEANING

To clean the unit, wipe its case with a dry, lint-free cloth. Do not use any cleaning fluids containing alcohol, ammonia or abrasives. Do not spray an aerosol at or near the unit.

## BATTERY DISPOSAL

Batteries may contain substances harmful to the environment. Please dispose of any discharged batteries with due consideration and in accordance with local environmental/electronic recycling guidelines.

## SERVICING

These units are not user serviceable. Never attempt to repair, disassemble or reconstruct the unit if there seems to be a problem. A serious electric shock could result if this precautionary measure is ignored. In the event of a problem or failure, please contact your dealer.



### WEEE SYMBOL

The crossed-out wheeled bin is the European Union symbol for indicating separate collection for electrical and electronic equipment. This product contains electrical and electronic equipment which should be reused, recycled or recovered and should not be disposed of with unsorted regular waste. Please return the unit or contact the authorised dealer from whom you purchased this product for more information.



### CE MARK

This product complies with European Low Voltage (2014/35/EU), Electromagnetic Compatibility (2014/30/EU) and Environmentally-friendly design of Energy-related Products (2009/125/EC) Directives when used and installed according to this instruction manual. For continued compliance only Cambridge Audio accessories should be used with this product and servicing must be referred to qualified service personnel.



### RCM (REGULATORY COMPLIANCE MARK)

This product meets Australia, New Zealand Safety, EMC and Radio Communications requirements of the ERAC and ACMA.



### CU-TR MARK

This product meets Russia, Byelorussia and Kazakhstan electronic safety approvals.



### Caution: Hot Surface. Do Not Touch

Both side heat sinks of the product may become hot when operating this product continuously.

Due to the surface of both heat sinks being unsuitable to attach a label, there is no sticker on the product.

## FCC STATEMENT

This device complies with Part 15 of the FCC Rules. Operation is subject to the following two conditions: (1) this device may not cause harmful interference, and (2) this device must accept any interference received, including interference that may cause undesired operation.

## Federal Communications Commission Notice:

This equipment has been tested and found to comply with the limits for a Class B digital device, pursuant to Part 15 of the FCC Rules. These limits are designed to provide reasonable protection against harmful interference in a residential installation.

This equipment generates, uses, and can radiate radio frequency energy, and if not installed and used in accordance with the instructions, may cause harmful interference to radio communications. However, there is no guarantee that interference will not occur in a particular installation.

If this equipment does cause harmful interference to radio or television reception, which can be determined by turning the equipment off and on, the user is encouraged to try and correct the interference by one or more of the following measures:

- Reorient or relocate the receiving antenna.
- Increase the distance between the equipment and the receiver.
- Connect the equipment to an outlet on a circuit different from that to which the receiver is connected.
- Consult the dealer or an experienced radio/TV technician for help.

**FCC Caution:** Any changes or modifications not expressly approved by the party responsible for compliance could void the user's authority to operate this equipment.

## RF Exposure Statement:

To maintain compliance with FCC's RF Exposure guidelines. This equipment should be installed and operated with a minimum distance of 20cm between the radiator and your body. Use only the supplied antenna.

## Modifications:

The FCC requires the user to be notified that any changes or modifications to this device that are not expressly approved by Cambridge Audio, may void the user's authority to operate the equipment.

## CANADA-INDUSTRY CANADA (IC)

This radio transmitter has been approved by Industry Canada.

This device complies with Industry Canada's license-exempt RSSs.

Operation is subject to the following two conditions.

(1) this device may not cause interference and (2) this device must accept any interference, including interference that may cause undesired operation of the device.

This equipment should be installed and operated with a minimum distance of 20cm between the radiator and your body.

The transmitter must not be co-located or operating in conjunction with any other antenna or transmitter.

The device meets the exemption from the routine evaluation limits in section 2.5 of RSS 102 and compliance with RSS-102 RF exposure, users can obtain Canadian information on RF exposure and compliance.

## INDUSTRIE CANADA (IC)

Le présent appareil est conforme aux CNR d'Industrie Canada applicables aux appareils radio exempts de licence. L'exploitation est autorisée aux deux conditions suivantes :

(1) l'appareil ne doit pas produire de brouillage, et (2) l'utilisateur de l'appareil doit accepter tout brouillage radioélectrique subi, même si le brouillage est susceptible d'en compromettre le fonctionnement.

Cet équipement doit être installé et utilisé à une distance minimale de 20 cm entre le radiateur et votre corps.

L'émetteur ne doit pas être co-placé ni fonctionner en conjonction avec une autre antenne ou transmetteur.

Le dispositif rencontre l'exemption des limites courantes d'évaluation dans la section 2.5 de RSS 102 et la conformité à l'exposition de RSS-102 rf, utilisateurs peut obtenir l'information canadienne sur l'exposition et la conformité de rf.

## EUROPE-EUROPEAN UNION NOTICE

Radio products with the CE marking comply with the RED Directive (2014/53/EU) issued by the Commission of the European Community.

Frequency: 2402 MHz-2480 MHz

The Max. transmit power: 5.30 dBm

This product can be used across EU member states.

Compliance with this directive implies conformity to the following European Norms.

- EN 60065 – Product Safety.
- EN 300 328 – Technical requirement for radio equipment.
- EN 301 489 – General EMC requirements for radio equipment.

# Front panel

## 1. STANDBY/ON

Switches the unit between Standby mode (indicated by dim LED) and On (indicated by bright LED). Standby mode is a low power mode where the power consumption is less than 0,5 Watts.

## AUTO POWER DOWN (APD)

The product will automatically switch to standby mode after inactivity of 20 minutes. To enable or disable this function, use the APD switch located on the rear of the unit.

## 2. IR SENSOR

Used for remote control.

## 3. VOLUME/SOURCE SELECTOR

To change the volume, rotate the front part. To select a source, rotate the back part.

## 4. HEADPHONES

For suitable headphones – connection will automatically mute the loudspeaker and pre-out.

## VOLUME CALIBRATION

The first time the Edge A is powered on after a factory reset, it will perform a calibration process, which takes approx. 30 seconds.

Please allow this process to complete before attempting to use the product.

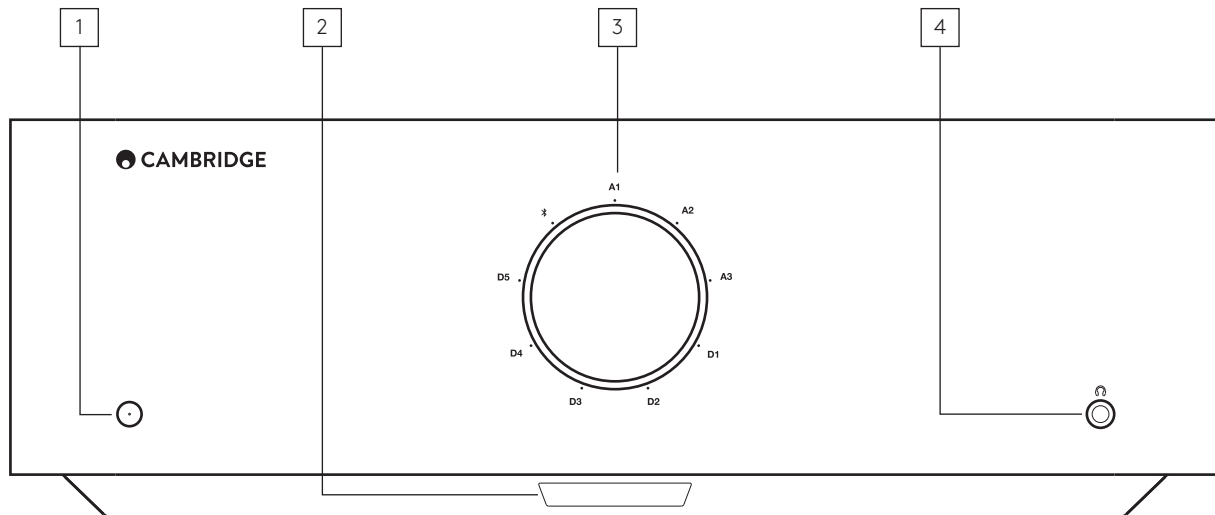

# Rear panel

## 1. VOLTAGE SELECTOR SWITCH

**Note:** For use by Cambridge Audio service personnel only!

## 2. AC POWER SOCKET

## 3. SPEAKER TERMINALS

## 4. PRE OUT

## 5. USB AUDIO IN (D5)

For connecting to PC/MAC computers.

(Class 2 USB Audio only. Windows based PCs require a Cambridge Audio USB driver to be installed before connection).

## 6. AUDIO RETURN CHANNEL (ARC)(D4)

Connection from a TV that supports ARC function

## 7. DIGITAL INPUTS (D1, D2 AND D3)

## 8. BLUETOOTH ANTENNA

Used for wireless streaming bluetooth audio capability directly from most phones, tablets and laptops. See later section for details.

## 9. BALANCED XLR (A3)/ UNBALANCED (A1 AND A2)

## 10. AUTO POWER DOWN (APD) SWITCH

## 11. LINK

Refer to the 'Power syncing' section of this manual for more information.

## 12. RS232

Custom install control - a full protocol is available for the Edge A on our website.

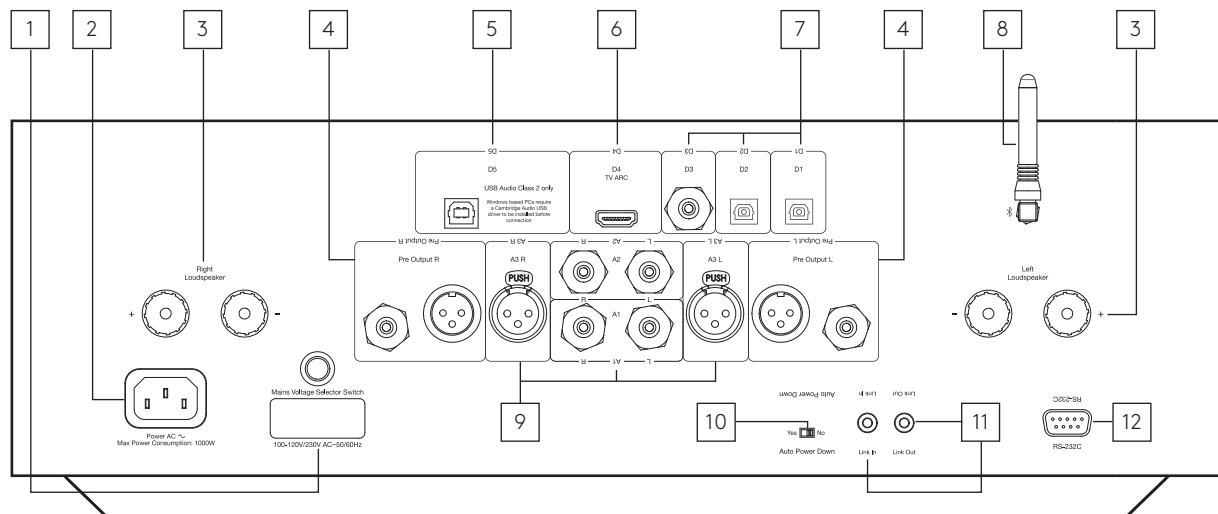

# Remote control

1. STANDBY/ON
2. VOLUME
3. SKIP
4. MUTE/UNMUTE
5. SOURCE SELECTOR
6. PROGRAMMABLE BUTTONS

Press and hold to store the current source and volume level.

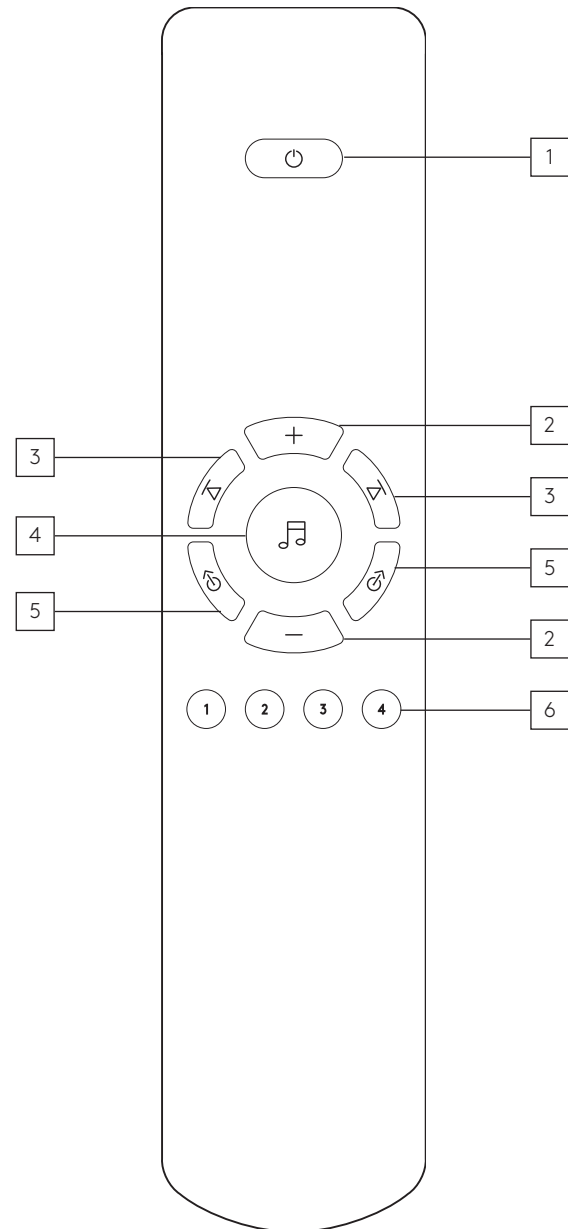

# Bluetooth

Selecting this allows the Edge A to receive wireless Bluetooth audio from most phones, tablets and laptops.

## PAIRING

To begin streaming high quality music from your chosen media source it will first need to be paired with the Edge A.

**Note:** Your device can only be paired and connected to the Edge A while the Bluetooth source is selected.

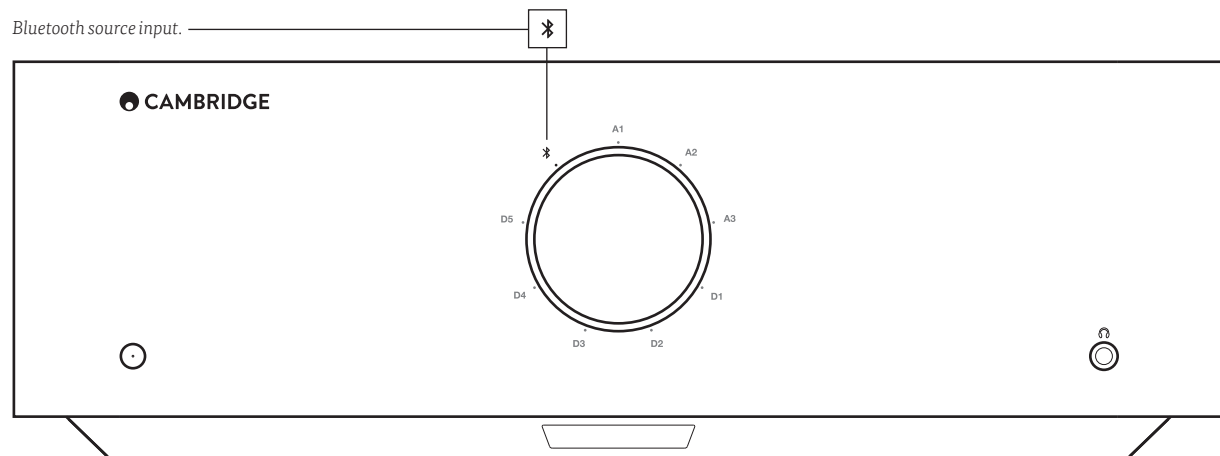



# Power syncing

Use the Link wire between the Edge A and Edge W to synchronise power on/standby.

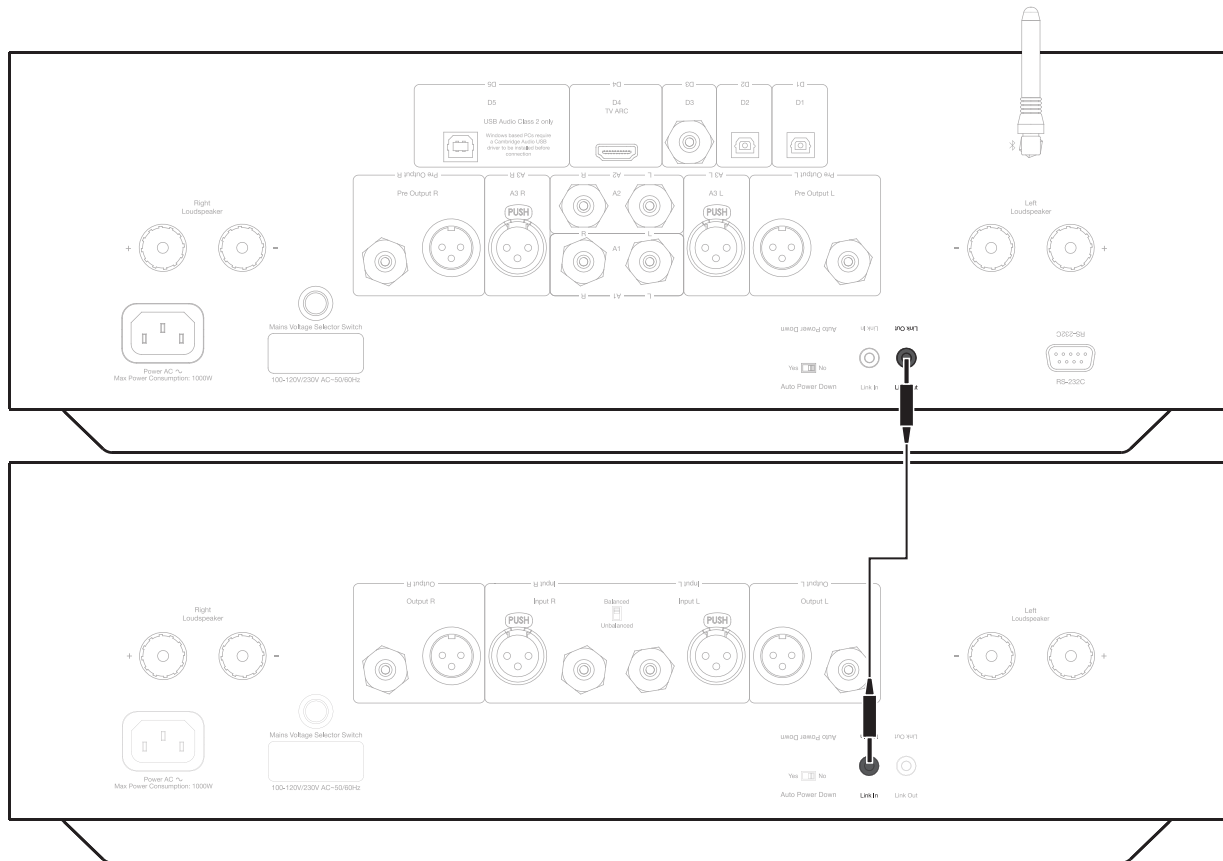

# Technical specification

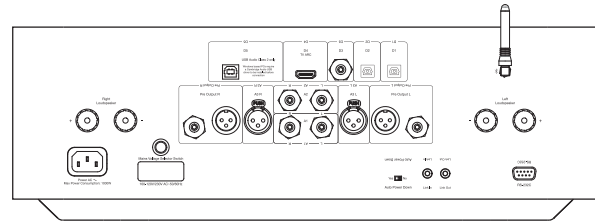
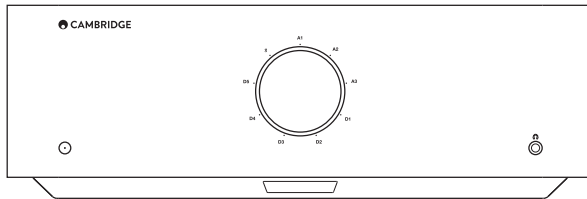

Continuous power output:	100W RMS into 8 Ohms 200W RMS into 4 Ohms
THD (unweighted):	<0.002% 1kHz at rated power (8 Ohms) <0.02% 20Hz - 20kHz at rated power (8 Ohms)
Frequency response:	<3Hz - >80kHz +/-1dB
S/N ratio (ref full power):	>103 dB
Crosstalk @ 1kHz:	< -100dB
Input sensitivity:	Input A1-A2 (unbalanced) 380mV RMS
Input impedances:	Input A3 (balanced) 47k Ohm Input A1-A2 (unbalanced) 47k Ohm
Inputs:	Balanced, Coax SPDIF, TOSLINK, USB Audio, Unbalanced, Bluetooth, Audio Return Channel (ARC)
Outputs:	Speakers, Preamplifier, Headphones (impedance of between 12 and 600 ohms are recommended)
USB audio input:	USB Audio Class 2.0 supporting up to 32-bit 384kHz PCM, or up to DSD256
Bluetooth:	4.1 (Smart/BLE enabled) A2DP/AVRCP supporting formats up to aptX HD
TOSLINK input:	16/24 bits, 32-96kHz
Coax SPDIF input:	16/24 bits, 32-192kHz
Max power consumption:	1000W
Standby power consumption:	<0.5W
Dimensions:	150 x 460 x 405mm (5.9 x 18.1 x 15.9")
Weight:	24.4kg (53.7lbs)

# Troubleshooting

If you experience any trouble with your Edge A, visit the help section on our webpage at <http://techsupport.cambridgeaudio.com>

## There is no power

- Ensure the AC power cord is connected securely.
- Ensure the plug is fully inserted into the wall socket and is switched on.
- Check fuse in the mains plug or adaptor.

## There is no sound

- Make sure the unit is not in Standby mode.
- Check that source component is properly connected.
- Check that your speakers are properly connected.
- Make sure unit is not in mute mode.

## There is no sound on one channel

- Check speaker connections.
- Check interconnects.

## There is a loud buzz or hum

- Ensure no interconnects are loose or defective.

## There is weak bass or diffused stereo imaging

- Ensure that speakers are not wired out of phase.

## The remote handset will not function

- Check that the batteries have not expired.
- Ensure that nothing is blocking the remote sensor.



[WWW.CAMBRIDGEAUDIO.COM](http://WWW.CAMBRIDGEAUDIO.COM)

Gallery Court, Hankey Place  
London SE1 4BB  
United Kingdom

Cambridge Audio is a brand of Audio Partnership Plc.  
Registered in England No. 2953313

AP34716/3