

F300 RANGE

FYNE ADVICE

ESSENTIAL INFORMATION GUIDE



FYNE
AUDIO

TABLE OF CONTENTS

1. Introduction
2. Safety
3. Plinth & Spike Fixing
4. F300 Wall Mounting
5. F300 LCR Wall Mounting
6. 2 Channel Positioning
7. AV Positioning
8. Connecting Speaker Cables
9. Connecting Speaker Cables (F303 Only)
10. Grilles
11. Cabinet Care
12. Warranty
13. Specifications

1 INTRODUCTION

Thank you for choosing Fyne Audio loudspeakers, proudly designed by our experienced team of engineers in Scotland, and constructed to the highest standards. We believe they will give you many years of listening pleasure.

2 SAFETY



For safety reasons, and to ensure you achieve the best performance possible, please fully read this document before installing these loudspeakers.

To prevent injury or damage when unpacking the loudspeakers, please do **not** use the protective bag to lift them in case it tears. If possible retain packaging for future use.

The spikes are very sharp - take care to avoid personal injury.

These speakers must always be connected to a suitable amplifier and **never** to a mains supply.

Ensure your amplifier is switched off before making connections, to avoid damage.

3 PLINTH AND SPIKE FITTING (F302, F303)

When assembling the plinth and fixing the spikes, always make sure the top of the cabinet is protected to avoid the risk of scratches and other damage.

Position the plinths in place on the bottom of the cabinet aligning the holes in the plinth with those on the bottom of the cabinet. Fix these securely, using the supplied bolts, spring-washers, washers and Allen key supplied (see Fig. 1).

Thread a nut onto each of the spikes and then screw each spike into the threaded inserts in each plinth, adjusting them all to approximately the same height (see Fig. 2). Once the loudspeaker is in place, adjust the spikes to ensure stability and use the lock-nut to secure them.

On wooden or other delicate floors, use the cups provided to prevent damage to the surface.

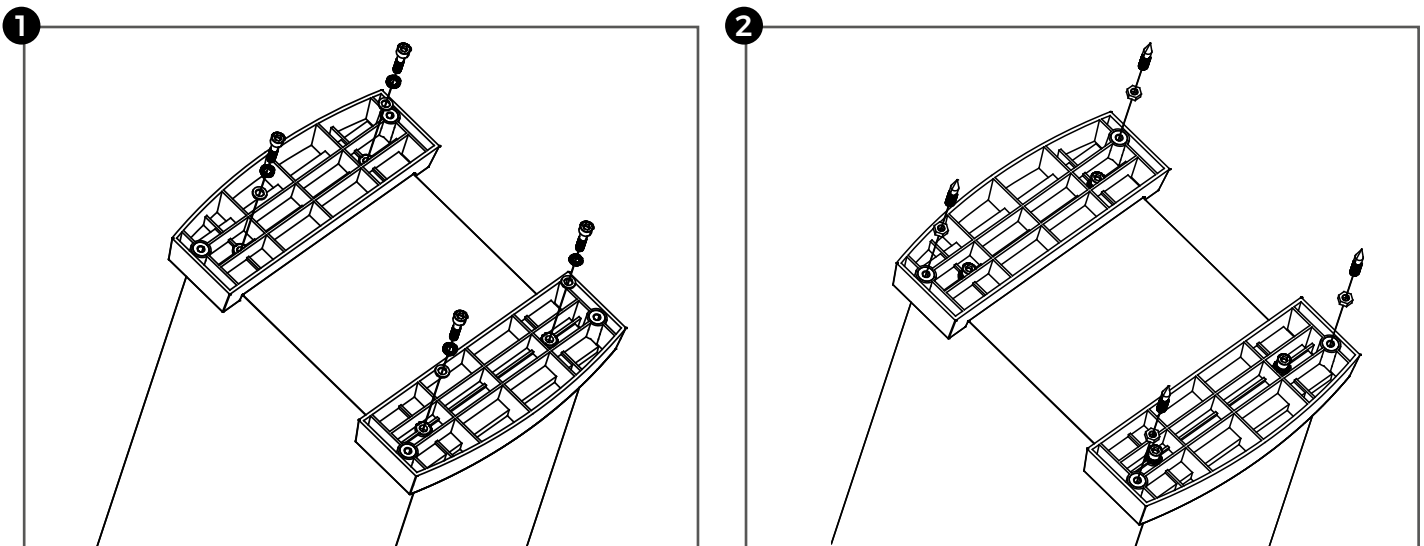

4 F300 WALL MOUNTING



The F300 has the option of wall mounting. A hanging point is provided on the rear of this model. It is the users' responsibility to provide appropriate fixing hardware. Ensure there are no water or gas pipes behind the wall drilling locations. If in doubt, consult a qualified tradesman. Ensure any steps are secure and be aware of trailing wires.

Place the supplied foam bung in the rear port to avoid air turbulence.

5 F300 LCR WALL MOUNTING



This model is designed to be wall mounted using the supplied template, to ensure correct fixing to the hanging points provided.

It is the users' responsibility to provide appropriate fixing hardware. Ensure there are no water or gas pipes behind the wall drilling locations. If in doubt, consult a qualified tradesman. Ensure any steps are secure and be aware of trailing wires.

6 TWO CHANNEL POSITIONING

The loudspeakers should be positioned approximately 1.5- 4.5m apart (5- 15 feet), ideally no closer than 0.5m (20 inches) from the rear wall, and no closer than 1m (3 feet) from the side walls (Fig.3).

Some degree of experimentation will provide the best results, especially with toe in towards the listener, to give

the best stereo imaging.

The F300 and F301 may be shelf mounted, but far better results will be obtained on dedicated stands that position the tweeter at ear level. Your dealer will be able to recommend suitable models.

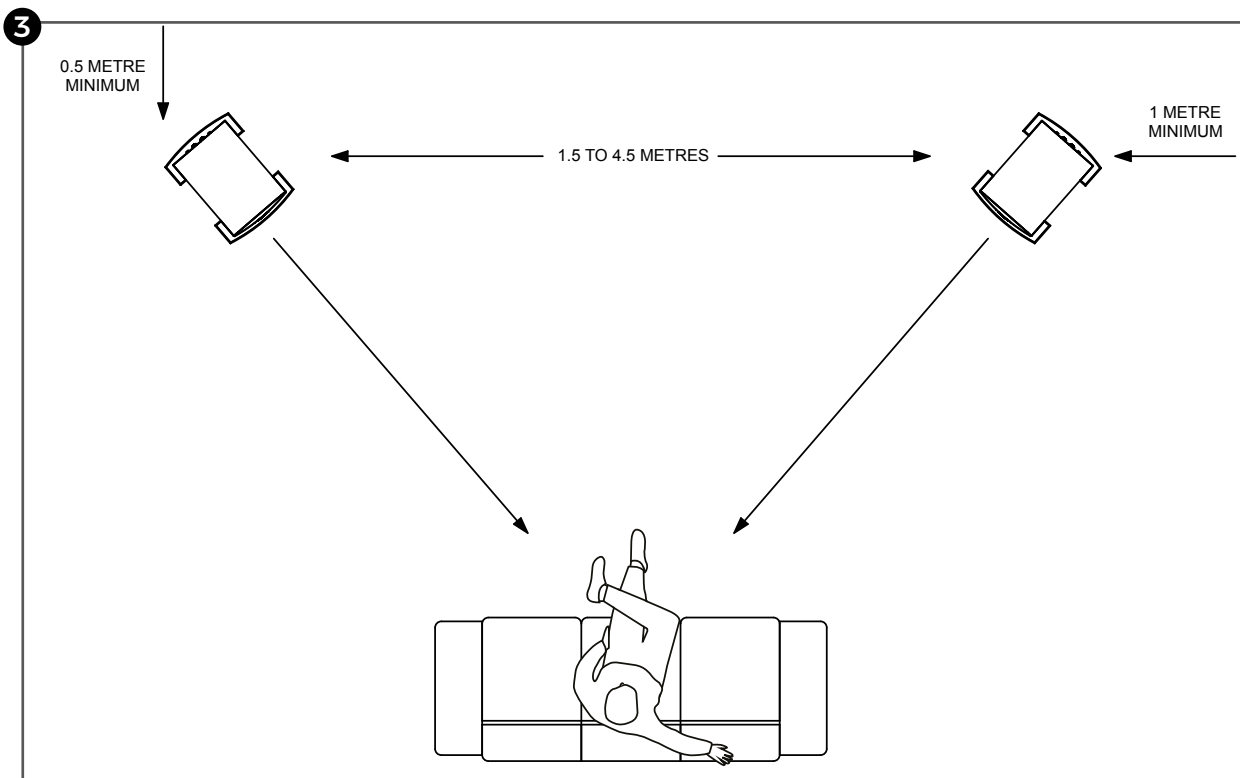

7 AV POSITIONING

The front speakers should be positioned as below for 2 channel operation, with the centre speaker equidistant between them and in the same plain, ideally at ear level.

When incorporating a subwoofer, please refer to the

instructions provided with it.

Stand mounting or floor standing models from the F300 range may be used for the rear effects loudspeakers (See Fig. 4).

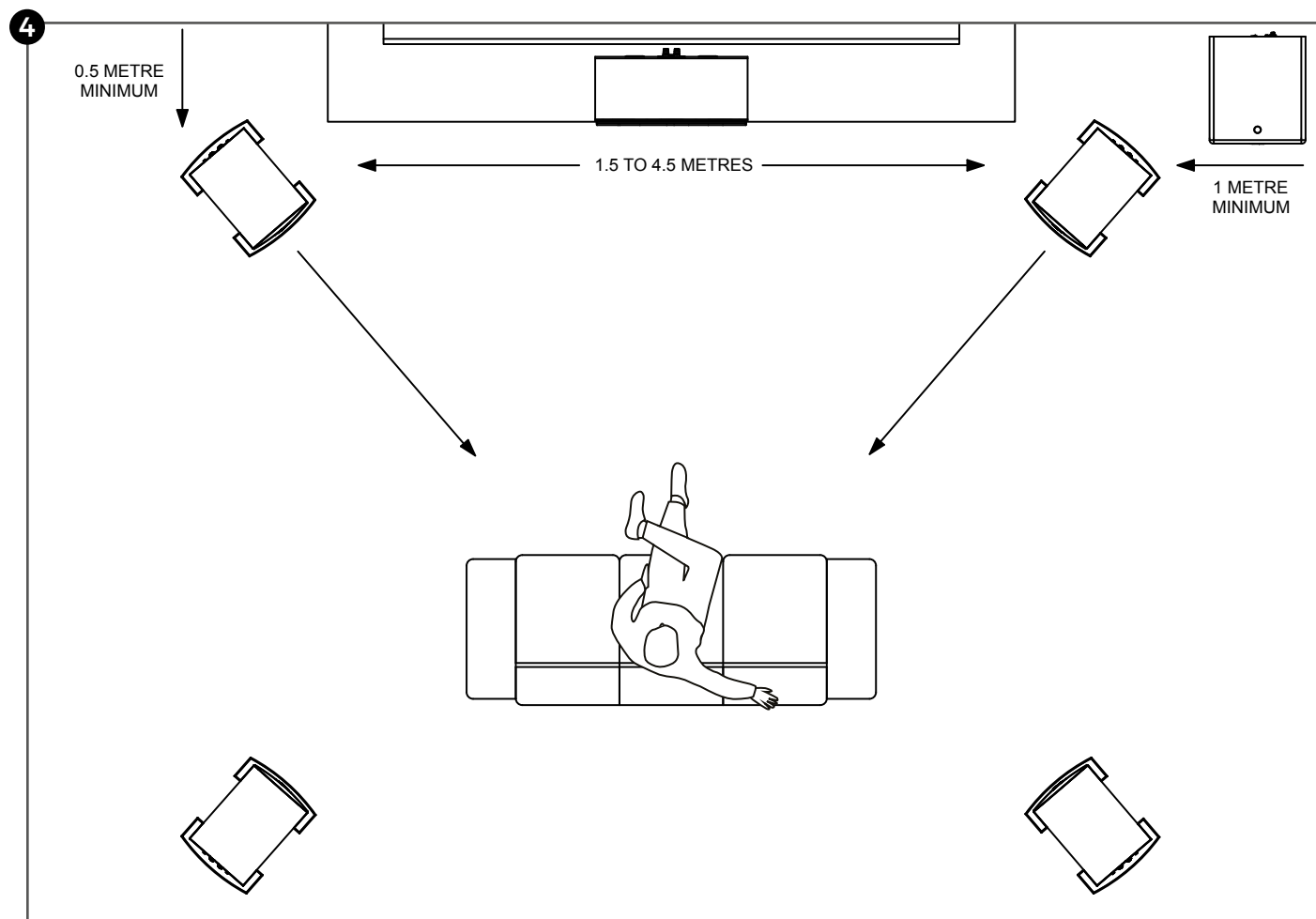

8 CONNECTING SPEAKER CABLES

Your dealer will be able to advise on the most suitable choice of cables for your budget and system, to obtain the best performance.

Bare wire connections may be made by unscrewing the terminal and making use of the hole in the threaded post. Alternatively, dedicated 4mm plugs may be purchased, or are already fitted to terminated cable sets (Fig. 5)

Ensure connections are made positive to positive and negative to negative between the speaker and the amplifier.

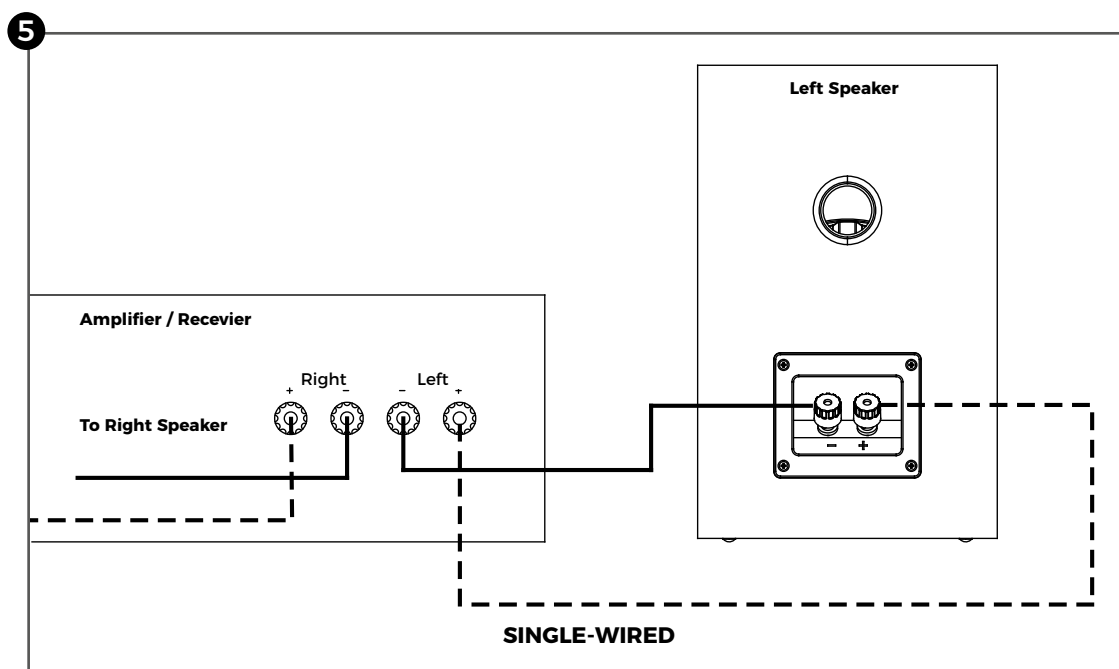

9 CONNECTING SPEAKER CABLES (F303 ONLY)

This model is provided with two sets of terminals, one for the HF and one for the LF. When using a single cable set, keep the link bars in place (Fig. 6). For bi-wire operation remove the link bars and wire with two sets of cable or a dedicated bi-wire cable (Fig. 7). This option will ensure the best possible sound quality.

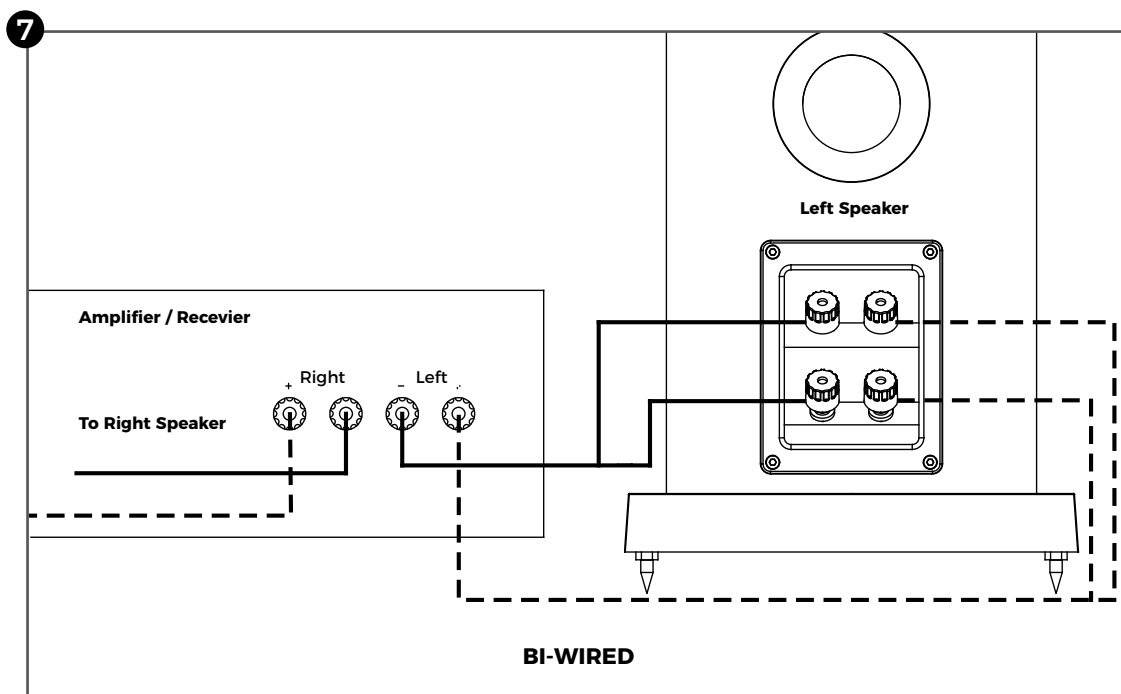
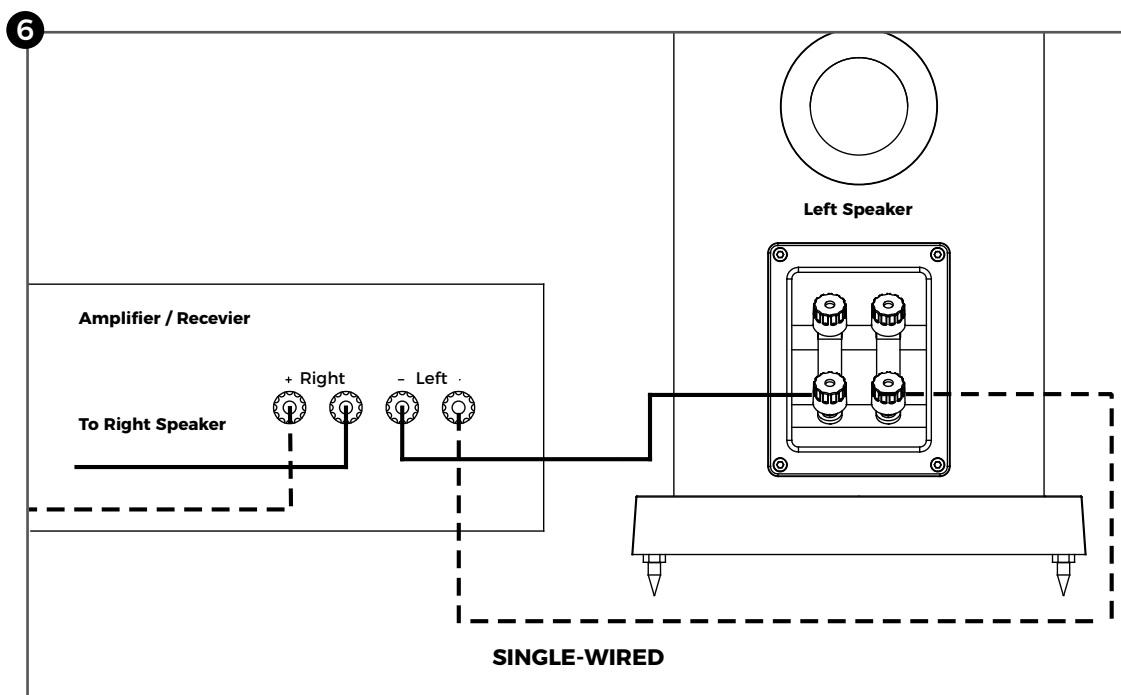

10 GRILLES

Although the magnetically attached grilles are designed for maximum transparency, we always recommend removal for the best possible sound quality.

11 CABINET CARE

The cabinet may be cleaned with a microfiber cloth. Avoid exposure to extremes of heat, humidity and direct sunlight for extended periods of time.

On no account use solvents or abrasive materials, as this will cause damage and invalidate the warranty.

12 WARRANTY

1. No maintenance of the loudspeaker is necessary.
2. Please register your Fyne Audio Limited product online at www.fyneaudio.com. All of our products have been produced and tested with care and precision to give first-class service.
3. All passive loudspeakers are guaranteed for a period of 7 years from the date of purchase from an authorised Fyne Audio Limited dealer. This warranty is subject to the absence or evidence of misuse, overload, or accidental damage, applies only to the registered owner, and covers only genuine Fyne Audio Limited products with the original undamaged serial number.
4. All active and electronic components are guaranteed for a period of 2 years from the date of purchase from an authorised Fyne Audio Limited dealer subject to the absence of, or evidence of, misuse, overload or accidental damage.
5. If at any time during this warranty period the equipment proves to be defective for any reason other than accident, misuse, neglect, unauthorised modification, incorrect installation or connection, matched with improper equipment or fair wear and tear, we will repair any such manufacturing defect or, at our option, replace it without charge for labour, parts or return carriage.
6. If you suspect a problem with a Fyne Audio Limited product, in the first instance, discuss it with your Fyne Audio Limited dealer. If you require further assistance, then we ask that you deal directly with your local Fyne Audio Limited distributor. If you cannot locate your distributor please contact Fyne Audio Limited Customer Services, via our website listed above or at the e-mail enquiries@fyneaudio.com
7. Do not ship any product to Fyne Audio Limited without previous authorisation.
8. **LIABILITY**
Other than the warranty and services set out in this warranty, to the fullest extent permitted by law, Fyne Audio Limited and its Authorised Distributors shall not be liable to you and/or any third party or entity whatsoever for:- any loss, damages and/or malfunction caused to any product(s) which is/are connected to any of the Fyne Audio Limited products any damages, loss and liability (except for any personal injuries or death), whether direct, indirect, incidental, consequential special, punitive or otherwise, howsoever caused by, arising out of, or otherwise in relation to the installation, delivery, use, service, repair, replacement and/or maintenance of the Fyne Audio Limited product; or any damages, loss and liability (except for any personal injuries or death) under this warranty in respect of any act, omission, or negligence of any of their technicians, employees, agents, representatives or independent contractors relating to the actual or purported performance of any of the obligations under this warranty.
9. Without limiting the above, the maximum liability of the Fyne Audio Limited and its Authorised Distributors under this warranty shall not in any event or under any circumstances exceed the actual purchase price paid for the Fyne Audio Limited product(s).

13 SPECIFICATIONS

Model	F300	F301	F302	F303
System type	2 way, rear ported	2 way, rear ported	2 way, rear ported	2 way, rear ported
Recommended amplifier power (Watt RMS)	20 - 70	35 - 150	40 - 180	30 - 120
Continuous power handling (Watt RMS)	35	50	60	75
Sensitivity (2.83 Volt @ 1m)	87dB	89dB	90dB	91dB
Nominal impedance	8 Ohm	8 Ohm	8 Ohm	8 Ohm
Frequency response (-6dB typical in room)	54Hz - 28kHz	44Hz - 28kHz	36Hz - 28kHz	32Hz - 28kHz
Drive unit complement	1 x 125mm multi-fibre bass / mid 1 x 25mm polyester dome tweeter	1 x 150mm multi-fibre bass / mid 1 x 25mm polyester dome tweeter	1 x 150mm multi-fibre bass / mid 1 x 25mm polyester dome tweeter	2 x 150mm multi-fibre bass / mid 1 x 25mm polyester dome tweeter
Crossover frequency	3.4kHz	3.2kHz	3.2kHz	3.2kHz
Crossover type	2nd order low pass, 1st order high pass	2nd order low pass, 3rd order high pass	2nd order low pass, 3rd order high pass	2nd order low pass, 3rd order high pass
Dimensions inc terminals, grille & plinth* - HxWxD	250 x 156 x 211mm (9.8 x 6.1 x 8.3")	300 x 190 x 271mm (11.8 x 7.5 x 10.7")	932 x 233 x 308mm * (36.7 x 9.2 x 12.1")	962 x 233 x 308mm * (37.9 x 9.2 x 12.1")

Model	F300C	F300LCR
System type	2 way, rear ported	2 way, closed box
Recommended amplifier power (Watt RMS)	25 - 100	25 - 100
Continuous power handling (Watt RMS)	50	50
Sensitivity (2.83 Volt @ 1m)	90dB	90dB
Nominal impedance	8 Ohm	8 Ohm
Frequency response (-6dB typical in room)	58Hz - 28kHz	80Hz - 28kHz
Drive unit complement	2 x 125mm multi-fibre bass / mid 1 x 25mm polyester dome tweeter	2 x 125mm multi-fibre bass / mid 1 x 25mm polyester dome tweeter
Crossover frequency	3.4kHz	3.4kHz
Crossover type	2nd order low pass, 1st order high pass	2nd order low pass, 1st order high pass
Dimensions incl terminals, grille & plinth* - HxWxD	156 x 400 x 211mm (6.1 x 15.8 x 8.3")	156 x 400 x 120mm (6.1 x 15.8 x 4.7")

Thank you for choosing Fyne Audio loudspeakers, proudly designed by our experienced team of engineers in Scotland, and constructed to the highest standards.

WWW.FYNEAUDIO.COM

 FYNEAUDIO

 @FyneAudio