

Supplemental to New Product Information (SNPI)

AP-505

Stereo Power Amplifier



An ultra-compact stereo power amplifier, powered by Hypex Ncore technology, designed to enable Bi-amping, or use in BTL (Bridge Tied Load/Bridged) mode

■ Features at-a-glance

- Hypex Ncore power amplifier module, tuned by TEAC
- 130W + 130W of max output power, or 250W in BTL mode
- 3 switchable output modes: Stereo, Bi-Amp and BTL (Bridge Tied Load/Bridged)
- Fully balanced circuit design, from input to output
- Power supply features large toroidal power transformer and Schottky barrier diodes
- Comprehensive protection circuitry (Current surge, Over-voltage, Over-heating)
- Patent-pending 'Pin-point' feet for easy installation (Japan Patent No.4075477, No.3778108)
- Large level meters
- XLR Balanced and RCA Unbalanced analog audio inputs



Brand	TEAC	TEAC
Series	Reference 505 series	
Model Name	AP-505-B	AP-505
Product name	Stereo Power Amplifier	Stereo Power Amplifier
Color	Black	Silver
UPC Code	043774000000	043774000000
EAN Code	4907034222483	4907034222476
Product W x H x D / NW	290 x 84.5 x 271 mm / 11.4" x 3.3" x 10.7" 4.4kg / 9.7 lbs.	
Package W x H x D / GW	440 x 190 x 340 mm / 17.3" x 7.5" x 13.4" 5.8kg / 12.8 lbs..	
Quantity per master carton	1 pc.	

Supplemental to New Product Information (SNPI)

■ Product overview

The AP-505 is a versatile stereo power amplifier based around a high-performance, TEAC-tuned, Hypex Ncore power amplifier module, housed within a compact and elegant case.

Capable of operating in bi-amp and BTL (Bridge Tied Load/Bridged) modes, in addition to conventional stereo operation, the AP-505 produces a maximum 130W + 130W of output power in stereo/bi-amp modes and 250W in BTL/bridged mode. At its heart is an Ncore power amplifier module, made by Hypex of the Netherlands and specially tuned by TEAC's R&D team, for superlative sound quality

As for the exterior, lightweight aluminum-alloy panels cover a robust steel chassis. A pair of large level meters add visual interest when the amplifier is in action, while TEAC's patent-pending 'Pin-point' feet, located at three strategic positions on the underside, add incision to the sound, helping to create a more detailed and stable stereo image.

● Latest Hypex Ncore amplifier technology, tuned by TEAC

The AP-505 employs a high-performance, energy-efficient Hypex Ncore power amplifier module which produces 130W + 130W in stereo/bi-amp modes or 250W in BTL mode. The module, which has undergone extensive listening tests before being carefully tuned and tweaked by our engineers, easily drives a wide range of speakers, delivering anything from a pianissimo to a fortissimo, and everything in between. In other words, it properly reproduces the dynamics of real music.

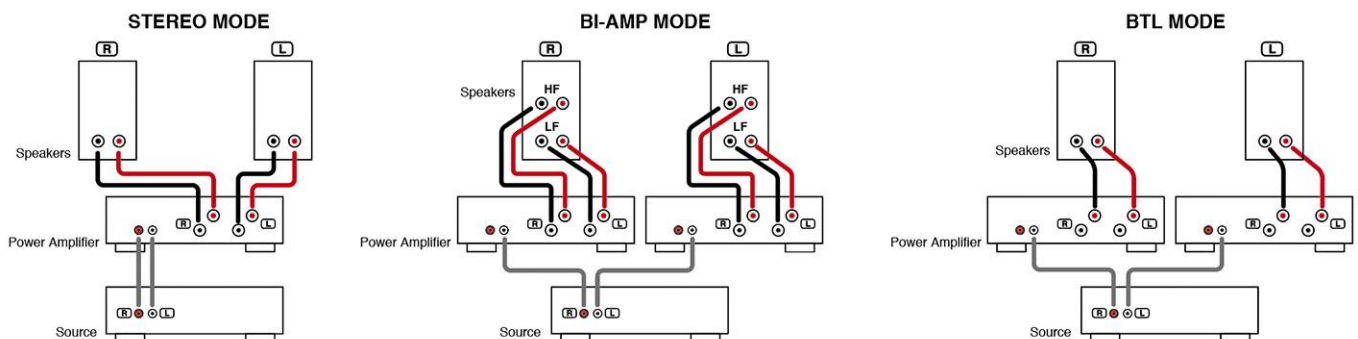

● Full-metal, small footprint body for rigidity, stability and elegance

Every external panel – at the front, top and sides - is formed from high-grade aluminium alloy, firmly attached to the robust steel inner chassis. This method of construction helps reduce the transmission of mechanical vibration, ensuring that every single element inside the unit is allowed to perform at its best. Thanks to its convenient A4-sized footprint, the AP-505 easily slots into modern interiors where space-efficiency is important, such as on a desktop. This is in stark contrast to most conventional bi-amp/BTL-capable power amplifiers which are usually bulky, full-width units.

● Fully-balanced design

By employing a fully-balanced circuit design from the input section to the output stage, the AP-505 keeps the audio signal as unadulterated as possible as it moves through the amplifier, the result

Supplemental to New Product Information (SNPI)

being extremely low distortion levels and an excellent signal-to-noise ratio (assisted by the effective elimination of common-mode noise).

● Carefully selected components, exclusively designed for hi-fi applications

At the input stage, where sound quality is fundamentally defined, high-quality MUSES8820E dual op-amps are employed for both the XLR and RCA inputs. In the power supply section for the input stage, both the left and right channel rectifying circuits are completely independent from the power transformer onwards, and employ four, high-capacity, 4700 μ F capacitors on each channel (8 in total), achieving clear soundstage separation between channels.

At the XLR input section, a well-designed circuit delivers excellent signal integrity, thanks in part to the elimination of coupling capacitors that can often lose audio information as a signal travels through them.

● An oversized toroidal power transformer

In the power supply, the AP-505 employs a high capacity toroidal-core transformer, with Schottky barrier diodes in the rectifying circuit. Unlike conventional diodes, Schottky barrier diodes reduce rectifier noise, leading to a 'cleaner' supply and a more stable delivery of current.

● 'Pin-Point' feet for easy installation

The AP-505 employs TEAC's patent-pending 'Pin-Point' feet. These comprise two separated metal sections in an integrated housing. One has a spiked top and is attached to the bottom of the chassis, the other is a basin-shaped base that hangs down from the spiked section, with a flange-shaped cup to simplify installation. As a result of the unique design, the 'Pin-Point' feet considerably minimize vibrations and resonance, by virtue of the fact that the unit is supported on just three points, with a very small surface contact area. This arrangement reduces mid and low frequency muddiness so improving the soundstage and enhancing fine sonic detail.

* Japan Patent numbers 4075477 and 3778108



● Passive-cooling design for silent operation

It makes no sense to design an amplifier that delivers excellent sound to a pair of speakers but which itself generates distracting operating noise from a cooling fan. From the outset our engineers were determined to use a circuit and layout that would allow sufficient natural cooling, one that would allow the creation of a compact but powerful amplifier which didn't need the help of a cooling fan.

● Dual analog level meters signal musical momentum

Analog level meters on the front panel move in response to signal levels, giving a visually pleasing confirmation that the amplifier is doing its job. A four-step dimmer (bright, mid, dim off) allows users to adjust the intensity of display to their taste, while a switchable sensitivity (± 0 dB, +20dB, movement off) allows you to enjoy more, less, or even no meter movement, if preferred.

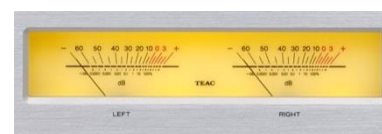

Naturally, even if the backlight is off and meter movement has been disabled, you are still able to tell the unit is on... by checking the position of power switch!

Supplemental to New Product Information (SNPI)

■ Key Features

- Hypex Ncore power amplifier module, tuned by TEAC
- 130W + 130W of max output power, or 250W in BTL/bridged mode
- Can operate in Stereo, Bi-Amp and BTL/bridged modes
- Fully balanced circuit design
- Carefully selected high-quality components, exclusively designed for Hi-Fi applications
- Large toroidal power transformer and Schottky barrier diodes
- Comprehensive protection circuits (Surge, Over-voltage, Thermal)
- Patent-pending 'Pin-point' feet for easy installation (Japan Patent No.4075477, No.3778108)
- Large level meters
- Passive-cooling for silent operation
- A4-sized footprint and full-metal body for rigidity, stability and elegance
- XLR Balanced and RCA Unbalanced analog audio inputs (one set of each)
- Wide-pitch, screw-type speaker terminals
- Auto power-saving
- RoHS compliant

■ Specifications

Amplifier section

Maximum output power

STEREO, BI-AMP mode	130 W + 130 W (4 ohms, 1kHz, JEITA)
	90 W + 90 W (8 ohms, 1kHz, JEITA)
BTL mode	250W (8 ohms, 1kHz, JEITA)

Rated output power

STEREO, BI-AMP mode	115 W + 115 W (4 ohms, 1kHz, THD 0.8%)
	70 W + 70 W (8 ohms, 1kHz, THD 0.8%)
BTL mode	220W (8 ohms, 1kHz, THD 0.8%)

Total harmonic distortion

0.0015 % (8 ohms, 1kHz, 12.5W, JEITA)

Signal-to-Noise ratio

113 dB (8 ohms, 1kHz, IHF-A)

Frequency response

10 Hz to 50,000 Hz (+0dB, -5dB, 8 ohms, 1W, JEITA)

Analog input section

LINE IN (Balanced)

XLR (2: HOT) x 1 pair

Input sensitivity 1.3V (output 8 ohms, THD 1%)

Input impedance 10k ohms or higher

LINE IN (Unbalance)

RCA (gold-plated) x 1 pair

Input sensitivity 0.66V (output 8 ohms, THD 1%)

Input impedance 10k ohms or higher

Output section

Speaker terminals

Screw type (gold-plated, compatible with banana-plug and AWG8) x 1 pair

Compatible speaker impedance

STEREO, BI-AMP mode 4 ohms to 16 ohms

BTL mode 8 ohms to 16 ohms

Supplemental to New Product Information (SNPI)



General

Operating power	AC 120V, 60Hz (US/Canada) AC 230V, 50Hz (UK/Europe)
Power consumption	106W
Standby power	0.1W or less (at Auto-power saving mode)
Overall dimensions (W x H x D)	290 x 84.5 x 271 mm / 11.4" x 3.3" x 10.7" (incl. protrusion)
Weight	4.4 kg / 9.7 lbs.
Operating temperature range	+5°C to +35°C / 41°F to 95°F
Operating humidity range	5% to 85% (no condensation)
Storage temperature range	-20°C to +55°C / -4°F to 131°F

Included items

- Power code
- Cushion for feet x 3pc
- Owner's manual (incl. Warranty)

■ Rear Panel

