

Upsampling digital to analogue converter

User's manual

ENGLISH

2



azur

DacMagic Plus

 **Cambridge Audio**

Your music + our passion

Make sure you register your purchase.

Visit: www.cambridge-audio.com/sts

By registering, you'll be the first to know about:

- **Future product releases**
- **Software upgrades**
- **News, events and exclusive offers plus competitions!**

This guide is designed to make installing and using this product as easy as possible. Information in this document has been carefully checked for accuracy at the time of printing; however, Cambridge Audio's policy is one of continuous improvement, therefore design and specifications are subject to change without prior notice.

This document contains proprietary information protected by copyright. All rights are reserved. No part of this manual may be reproduced by any mechanical, electronic or other means, in any form, without prior written permission of the manufacturer. All trademarks and registered trademarks are the property of their respective owners.

© Copyright Cambridge Audio Ltd 2011.

Cambridge Audio and the Cambridge Audio logo are trademarks of Cambridge Audio.

Other brands mentioned are trademarks of their respective owners and are used for reference purposes only.

Cambridge Audio's policy of continuous improvement means design and specification may change without notice.

The Bluetooth® word mark and logos are registered trademarks owned by Bluetooth SIG, Inc.

apt-X® is a registered trademark of APT Ltd.

Contents

Introduction	4
Important safety instructions	6
Limited warranty.....	12
Rear panel connections.....	14
Front panel controls.....	17
Audio output connections.....	19
Digital audio input connections	20
PC-USB connections	21
Digital audio output connections.....	25
BT100 Bluetooth interface	26
Operating instructions	30
Filters	31
Technical specifications.....	38
Troubleshooting.....	39

This package should contain the following:

1 x Azur DacMagic Plus (assembled), 1 x AC power adaptor, 4 x rubber feet, 1 x rubber base,
1 x USB 'B-A' type lead, 1 x user's manual.

Introduction

Thank you for purchasing this Cambridge Audio DacMagic Plus Upsampling Digital to Analogue Converter. We are confident that you will enjoy many years of listening pleasure from it. Like all Cambridge Audio products, the DacMagic Plus adheres to our three core principles – stunning performance, ease of use and incredible value

The DacMagic Plus features ATF2™ (2nd Adaptive Time Filtering), an up-sampling process developed in conjunction with Anagram Technologies of Switzerland to intelligently interpolate incoming audio data to 24-bit/384kHz through the use of a 32-bit Analog Devices DSP (Digital Signal Processor). The ATF2 system applies sophisticated polynomial curve-fitting interpolation and incorporates a time domain model which adaptively generates the new data in the temporal domain, dramatically reducing digital jitter.

Our latest version of this algorithm now supports noise shaped data scrambling for enhanced linearity with 24-bit content.

As with our high-end CD players, our proprietary Dual Differential Virtual Earth Balanced filter topology is used, configured as a low-order two pole linear-phase Bessel filter to take advantage of the high sampling rate achieved. Two very high quality Wolfson WM8740 24-bit DAC ICs are used in dual differential mode. Since each channel has its own DAC to process information, completely separate and symmetrical analogue filter circuitry can be implemented. These allow both left- and right-channel circuitry to operate identically, ensuring the DacMagic Plus delivers fantastic sound-staging and stereo-imaging properties.

Two digital inputs are fitted (both featuring S/P DIF and TOSLINK) and allow a wide range of digital sources to be connected. In addition, a USB input enables the DacMagic Plus to be connected to a PC and act as a very high quality DAC/Soundcard, offering genuine HiFi-quality playback from your desktop, media PC, etc. A digital output is fitted which passes through the selected digital source for recording purposes (no up-sampling performed).

Up to 24-bit content is now supported via both the USB Audio and Digital Inputs.

With Windows PCs the DacMagic Plus can operate driverlessly (i.e. use Windows own built-in driver) at up to 24-bit/96kHz resolution.

In addition our own Windows driver (downloadable from www.cambridge-audio.com/DacMagicPlus-Support) allows up to 24-bit/192kHz operation and supports both kernel streaming and ASIO.

Mac PCs already support up to 24-bit/192kHz USB transfer natively.

A high quality headphone output allows personal listening and an optional digital preamp mode allows the DacMagic Plus to be used directly into a power amp or active speakers if so desired.

Your DacMagic Plus can only be as good as the system it is connected to. Please do not compromise on your amplifier, speakers or cabling. Naturally, we particularly recommend amplification from the Cambridge Audio range. Your dealer can also supply excellent quality Cambridge Audio interconnects to ensure your system realises its full potential.

Thank you for taking the time to read this manual; we recommend you keep it for future reference.



Matthew Bramble
Cambridge Audio Technical Director
and the DacMagic Plus design team

Important safety instructions

For your own safety please read the following important safety instructions carefully before attempting to connect this unit to the mains power supply. They will also enable you to get the best performance from and prolong the life of the unit:

1. Read these instructions.
2. Keep these instructions.
3. Heed all warnings.
4. Follow all instructions.
5. Do not use this apparatus near water.
6. Clean only with a dry cloth.
7. Do not block any ventilation openings. Install in accordance with the manufacturer's instructions.
8. Do not install near any heat sources such as radiators, heat registers, stoves, or other apparatus (including amplifiers) that produce heat.
9. Do not defeat the safety purpose of the polarized or grounding-type plug. A polarized plug has two blades with one wider than the other. A grounding-type plug has two blades and a third grounding prong. The wide blade or the third prong are provided for your safety. If the provided plug does not fit into your outlet, consult an electrician for replacement of the obsolete outlet.
10. Protect the power cord from being walked on or pinched, particularly at plugs, convenience receptacles and the point where they exit from the apparatus.
11. Only use attachments/accessories specified by the manufacturer.
12. Unplug this apparatus during lightning storms or when unused for long periods of time.
13. Refer all servicing to qualified service personnel. Servicing is required when the apparatus has been damaged in any way, such as the power-supply adaptor having been damaged, liquid has been spilled or objects have fallen into the apparatus, the apparatus has been exposed to rain or moisture, does not operate normally, or has been dropped.

WARNING

- To reduce the risk of fire or electric shock, do not expose this unit to rain or moisture.

The unit must be installed in a manner that makes disconnection of the mains adaptor from the mains socket outlet (or appliance connector from the rear of the unit) possible. Where the mains adaptor is used as the disconnect device, the disconnect device shall remain readily operable. Only use the mains adaptor supplied with this unit.

Please ensure there is ample ventilation (at least 10cm clearance all round). Do not put any objects on top of this unit. Do not situate it on a rug or other soft surface and do not obstruct any air inlets or outlet grilles.

This unit must not be used near water or exposed to dripping or splashing water or other liquids. No objects filled with liquid, shall be placed on the unit.



The lightning flash with the arrowhead symbol within an equilateral triangle is intended to alert the user to the presence of un-insulated 'dangerous voltage' within the product's enclosure that may be of sufficient magnitude to constitute a risk of electric shock to persons.

The exclamation point within an equilateral triangle is intended to alert the user to the presence of important operating and maintenance instructions in the service literature relevant to this appliance.



WEEE symbol

The crossed-out wheeled bin is the European Union symbol for indicating separate collection for electrical and electronic equipment. This product contains electrical and electronic equipment which should be reused, recycled or recovered and should not be disposed of with unsorted regular waste. Please return the unit or contact the authorised dealer from whom you purchased this product for more information.



CE mark

This product complies with European Low Voltage (2006/95/EC), Electromagnetic Compatibility (2004/108/EC) and Environmentally-friendly design of Energy-related Products (2009/125/EC) Directives when used and installed according to this instruction manual. For continued compliance only Cambridge Audio accessories should be used with this product and servicing must be referred to qualified service personnel.



C-Tick mark

This product meets the Australian Communications Authority's Radio communications and EMC requirements.



Gost-R mark

This product meets Russian electronic safety approvals.

FCC regulations

NOTE: THE MANUFACTURER IS NOT RESPONSIBLE FOR ANY RADIO OR TV INTERFERENCE CAUSED BY UNAUTHORIZED MODIFICATIONS TO THIS EQUIPMENT. SUCH MODIFICATIONS COULD VOID THE USER AUTHORITY TO OPERATE THE EQUIPMENT.



This equipment has been tested and found to comply with the limits for a Class B digital device, pursuant to Part 15 of the FCC Rules. These limits are designed to provide reasonable protection against harmful interference in a residential installation. This equipment generates, uses and can radiate radio frequency energy and, if not installed and used in accordance with the instructions, may cause harmful interference to radio communications. However, there is no guarantee that interference will not occur in a particular installation.

If this equipment does cause harmful interference to radio or television reception, which can be determined by turning the equipment off and on, the user is encouraged to try to correct the interference by one or more of the following measures:

- Re-orient or relocate the receiving antenna.
- Increase the separation between the equipment and receiver.
- Connect the equipment into an outlet on a circuit different from that to which the receiver is connected.
- Consult the dealer or an experienced radio/TV technician for help.

Ventilation

IMPORTANT – The unit will become warm when in use. Do not stack multiple units on top of each other. Do not place in an enclosed area such as a bookcase or in a cabinet without sufficient ventilation.

Ensure that small objects do not fall through any ventilation grille. If this happens, switch off immediately, disconnect from the mains supply and contact your dealer for advice.

Positioning

Choose the installation location carefully. Avoid placing it in direct sunlight or close to a source of heat. No naked flame sources, such as lighted candles, should be placed on the unit. Also avoid locations subject to vibration and excessive dust, cold or moisture. The unit can be used in a moderate climate.

This unit must be installed on a sturdy, level surface. Do not place in a sealed area such as a bookcase or in a cabinet. Do not place the unit on an unstable surface or shelf. The unit may fall, causing serious injury to a child or adult as well as serious damage to the product. Do not place other equipment on top of the unit.

Due to stray magnetic fields, turntables or CRT TVs should not be located nearby due to possible interference.

Electronic audio components have a running in period of around a week (if used several hours per day). This will allow the new components to settle down and the sonic properties will improve over this time.

Power sources

The unit should be operated only from the type of power source indicated on the marking label. If you are not sure of the type of power-supply to your home, consult your product dealer or local power company.

To turn the unit off, switch off at the front panel. If you do not intend to use this unit for a long period of time, unplug it from the mains socket.

Overloading

Do not overload wall outlets or extension cords as this can result in a risk of fire or electric shock. Overloaded AC outlets, extension cords, frayed power cords, damaged or cracked wire insulation and broken plugs are dangerous. They may result in a shock or fire hazard.

Be sure to insert each power cord securely. To prevent hum and noise, do not bundle the interconnect leads with the power cord or speaker leads.

Cleaning

To clean the unit, wipe its case with a dry, lint-free cloth. Do not use any cleaning fluids containing alcohol, ammonia or abrasives. Do not spray an aerosol at or near the unit.

Servicing

These units are not user serviceable. Never attempt to repair, disassemble or reconstruct the unit if there seems to be a problem. A serious electric shock could result if this precautionary measure is ignored. In the event of a problem or failure, please contact your dealer.

Limited warranty

Cambridge Audio warrants this product to be free from defects in materials and workmanship (subject to the terms set forth below). Cambridge Audio will repair or replace (at Cambridge Audio's option) this product or any defective parts in this product. Warranty periods may vary from country to country. If in doubt consult your dealer and ensure that you retain proof of purchase.

To obtain warranty service, please contact the Cambridge Audio authorised dealer from which you purchased this product. If your dealer is not equipped to perform the repair of your Cambridge Audio product, it can be returned by your dealer to Cambridge Audio or an authorised Cambridge Audio service agent. You will need to ship this product in either its original packaging or packaging affording an equal degree of protection.

Proof of purchase in the form of a bill of sale or receipted invoice, which is evidence that this product is within the warranty period, must be presented to obtain warranty service.

This Warranty is invalid if (a) the factory-applied serial number has been altered or removed from this product or (b) this product was not purchased from a Cambridge Audio authorised dealer. You may call Cambridge Audio or your local country Cambridge Audio distributor to confirm that you have an unaltered serial number and/or you made a purchase from a Cambridge Audio authorised dealer.

This Warranty does not cover cosmetic damage or damage due to acts of God, accident, misuse, abuse, negligence, commercial use, or modification of, or to any part of, the product. This Warranty does not cover damage due to improper operation, maintenance or installation, or attempted repair by anyone other than Cambridge Audio or a Cambridge Audio dealer, or authorised service agent which is authorised to do Cambridge Audio warranty work. Any unauthorised repairs will void this Warranty. This Warranty does not cover products sold AS IS or WITH ALL FAULTS.

REPAIRS OR REPLACEMENTS AS PROVIDED UNDER THIS WARRANTY ARE THE EXCLUSIVE REMEDY OF THE CONSUMER. CAMBRIDGE AUDIO SHALL NOT BE LIABLE FOR ANY INCIDENTAL OR CONSEQUENTIAL DAMAGES FOR BREACH OF ANY EXPRESS OR IMPLIED WARRANTY IN THIS PRODUCT. EXCEPT TO THE EXTENT PROHIBITED BY LAW, THIS WARRANTY IS EXCLUSIVE AND IN LIEU OF ALL OTHER EXPRESS AND IMPLIED WARRANTIES WHATSOEVER INCLUDING, BUT NOT LIMITED TO, THE WARRANTY OF MERCHANTABILITY AND FITNESS FOR A PRACTICAL PURPOSE.

Some countries and US states do not allow the exclusion or limitation of incidental or consequential damages or implied warranties so the above exclusions may not apply to you. This Warranty gives you specific legal rights, and you may have other statutory rights, which vary from state to state or country to country.

For any service, in or out of warranty, please contact your dealer.

Plug fitting instructions (UK only)

The cord supplied with this appliance is factory-fitted with a UK mains plug fitted with a 5-amp fuse inside. If it is necessary to change the fuse, it is important that a 5-amp fuse is used. If the plug needs to be changed because it is not suitable for your socket, or becomes damaged, it should be cut off and an appropriate plug fitted following the wiring instructions below. The plug must then be disposed of safely, as insertion into a mains socket is likely to cause an electrical hazard. Should it be necessary to fit a 3-pin BS mains plug to the power cord, the wires should be fitted as shown in this diagram. The colours of the wires in the mains lead of this appliance may not correspond with the coloured markings identifying the terminals in your plug. Connect them as follows:

The wire which is coloured BLUE must be connected to the terminal which is marked with the letter 'N' or coloured BLACK.

The wire which is coloured BROWN must be connected to the terminal which is marked with the letter 'L' or coloured RED.

The wire which is coloured GREEN/YELLOW must be connected to the terminal which is marked with the letter 'E' or coloured GREEN.

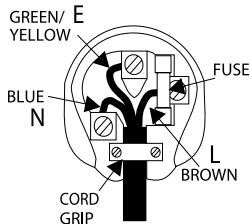

If a standard 13-amp (BS 1363) plug is used, a 5-amp fuse must be fitted or, if any other type of plug is used, a 5-amp fuse must be fitted, either in the plug or adaptor, or on the distribution board.

Rear panel connections

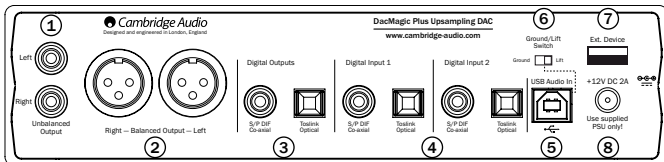

① Unbalanced audio outputs

Single-ended conventional stereo outputs for connection to the line-level Phono/RCA inputs of an amplifier.

② Balanced audio outputs

The DacMagic Plus also features true balanced (XLR) outputs. This is a higher quality output that can reject noise and interference when used with equipment with balanced inputs. These balanced outputs are ideally suited for connection to amplifiers that feature this connection such as our own 8 - series. XLR connectors should be wired as follows:

Pin 1 – Ground; Pin 2 – Hot (in-phase); Pin 3 – Cold (phase-inverted).

Note:

The DacMagic Plus is supplied as default with Digital Preamp mode enabled. In this mode the output from the Unbalanced and Balanced audio outputs is controlled by the front panel Volume control.

If you wish to disable this mode (and have fixed line-level level output from the Unbalanced and Balanced Audio outputs) switch the DacMagic Plus off, then push and hold the Volume control in whilst switching the DacMagic Plus on.

The DacMagic Plus confirms the setting by flashing the source LEDs downwards for Digital Preamp Mode and upwards for Fixed Line Level Mode.

③ Digital outputs

The digital outputs allow a digital recording device to be connected. These outputs loop or pass-through unprocessed digital audio from the selected digital input. Two types are available (both the co-axial and the optical are active concurrently and can be used to connect and run equipment at the same time):

S/P DIF co-axial – to obtain best results, use a high quality 75 ohm digital RCA interconnect cable (not one designed for normal audio use).

TOSLINK optical – use a high quality TOSLINK fibre-optic interconnect cable designed specifically for audio use. To achieve the best results we always recommend using high quality Cambridge Audio leads, which are guaranteed for life.

Note: These outputs are pass-through only; there is no upsampling or any other modification done to the LPCM input signal.

④ Digital inputs 1 and 2

The DacMagic Plus is fitted with two sets of digital inputs which enable the connection of source components. Each input has both S/P DIF and TOSLINK types fitted. Only one of the two types for each input should be connected at any one time. If both the optical and co-axial outputs have connections made to them, neither will work.

S/P DIF co-axial – to obtain best results, use a high quality 75 ohm digital RCA interconnect cable (not one designed for normal audio use).

TOSLINK optical – use a high quality TOSLINK fibre-optic interconnect cable designed specifically for audio use.

Note: This unit only accepts two-channel LPCM digital audio (e.g. Stereo PCM or Dolby Digital 2.0). You cannot connect a Dolby Digital 5.1 or a DTS signal as they will not be recognised. If you wish to connect a DVD or similar device, please ensure that the sound output of your player is set to two-channel PCM.

⑤ USB in

A USB B type socket is fitted to the DacMagic Plus to enable the playback of audio from a personal computer running either Microsoft Windows or Apple Mac OS X operating systems. Some builds of Linux are also suitable.

Note: Always use a certified cable for USB Audio, preferably one that displays an official mark. For USB Audio 2.0 the cable should be the 'Hi-Speed USB' certified. USB cable connections longer than 3m may result in inconsistent audio performance.

⑥ Ground/Lift switch

When Grounded the Dacmagic Plus is connected to the earth connection of the PC directly. When Lifted the ground connection is made via a network designed to break any hum loops that may be caused by the source equipment.

We advise using the Grounded setting unless audible hum is experienced.

⑦ Ext. device

Allows connectivity of USB audio enabled Cambridge Audio accessories, such as the BT100 Bluetooth adaptor.

⑧ DC 12V 1.5A power adaptor socket

Once you have completed all connections, plug the supplied power adaptor into the DacMagic Plus.

Important Note: Use the supplied power supply unit **ONLY**.

Front panel controls

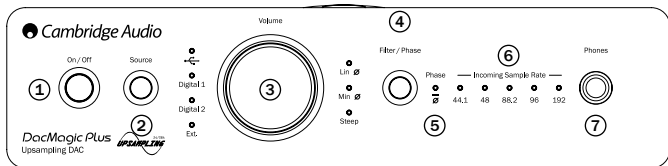

① Power on/off

Switches the unit between on and off.

② Source

Press to select between USB, External (Ext.) or Digital Inputs 1 and 2. The corresponding LED will light up to show which source has been selected.

③ Digital volume control

When headphones are connected, the headphone volume can be adjusted using the volume knob.

Note: This is always independent of the level of the balanced or unbalanced audio outputs.

If the Dacmagic Plus has been placed in Digital Preamp mode the Volume control also adjusts the output of the Unbalanced and Balanced Audio outputs.

Rotating the volume control counter clockwise beyond minimum volume turns on Mute (DacMagic Plus flashes the source LED constantly).

Rotating the volume control clockwise until maximum volume is achieved causes the DacMagic Plus to briefly flash the source LED.

Further rotations in the same direction in either case do nothing.

④ **Filter/Phase select**

Momentarily press to select between three different filter modes: linear phase, minimum phase or steep, see later section for details. The corresponding LED will light up to show which filter has been selected.

⑤ **Phase**

Press and hold the Filter/Phase select button for approximately two seconds to select normal or inverted phase output. When the LED lights up, the phase is inverted by the DacMagic Plus.

If you suspect that your source material or amplifier, etc., is inverting the phase of the musical signal, you can use this function to re-invert the audio and regain absolute positive phase.

⑥ **Incoming sample rate**

In the presence of an incoming digital stream, the relevant LED will light up to indicate the incoming digital sampling frequency (between 44.1kHz and 192kHz LPCM). For 32kHz material, the DacMagic Plus will still operate but no LED will be lit.

⑦ **Headphone connection**

Allows for the connection of headphones with a 1/4" jack plug connector. Headphones with an impedance of between 32 and 600 ohms are recommended

Audio output connections

Note: Do not turn on the unit until all connections have been made.

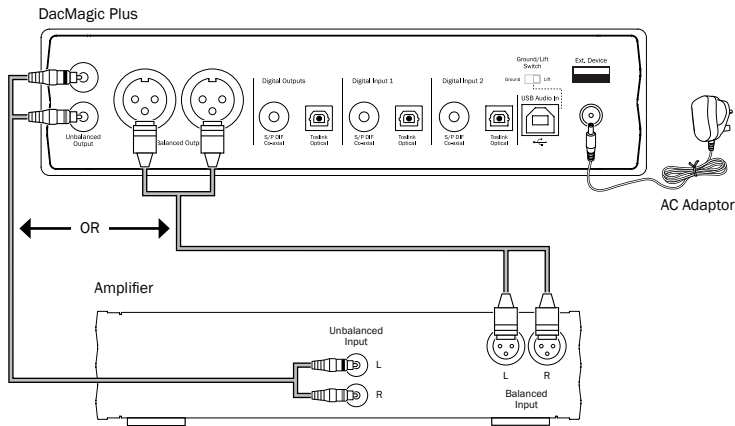

Use either the unbalanced (RCA/Phono) or balanced (XLR) outputs of the DacMagic Plus. The XLR output is slightly better in quality as it can reject interference and noise in the cable connection and is the preferred option if your amplifier features balanced XLR inputs. It is possible to use the RCA phono connections and the XLR balanced connections at the same time, e.g. for connecting to different amplifiers or multi-room operations.

Digital audio input connections

Note: Do not turn on the unit until all connections have been made.

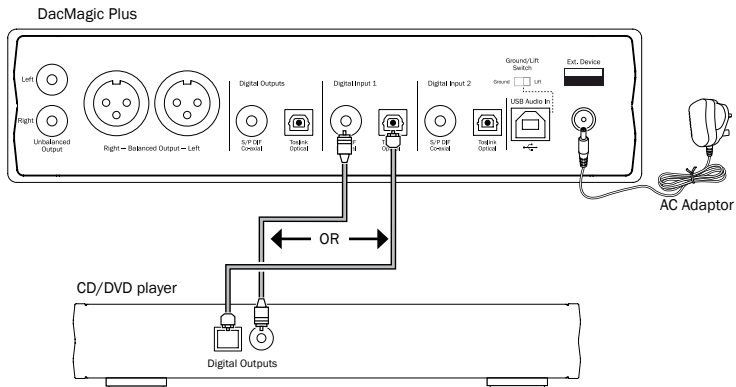

Connect your digital source to Digital Input 1 or 2. Either S/P DIF co-axial or TOSLINK optical types can be used, each being of equal quality.

Important Note: Only connect one co-axial OR optical cable to each digital input. The unit will not operate if both connections are made (even if only one is active).

PC-USB connections

Note: Do not turn on the unit until all connections have been made.

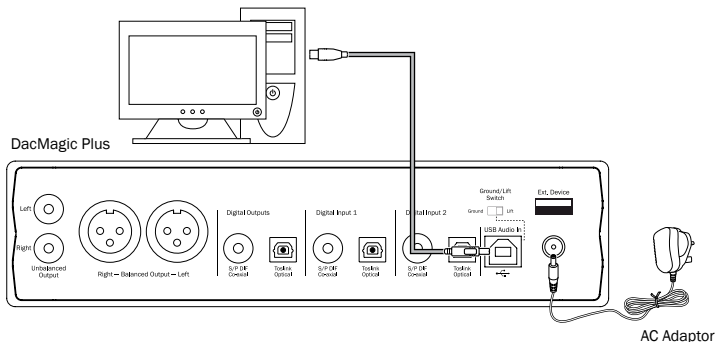

USB 'B-A' type lead

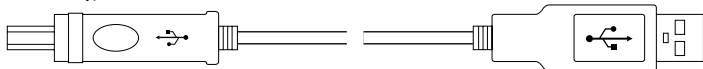

Note: Always use a certified cable for USB Audio, preferably one that displays an official mark. For USB Audio 2.0 the cable should be the 'Hi-Speed USB' certified. USB cable connections longer than 3m may result in inconsistent audio performance.

Advanced USB audio

The DacMagic Plus is both USB 2.0 (Hi-Speed) and USB 1.1 (Full-speed) USB port compatible.

It will also work with the new USB 3.0 ports where the PC will simply treat the DacMagic Plus as if it were a USB 2.0 or 1.1 device.

The DacMagic Plus also supports two USB Audio protocols (not the same as the port types themselves) USB Audio 1.0 (which works over USB 1.1 ports and supports up to 24-bit/96kHz) or USB Audio 2.0 (which requires a USB 2.0 port and can support up to 24-bit/192kHz).

The default configuration is USB 1.1 and USB Audio 1.0 which works with nearly all common operating systems and computer types without drivers and supports up to 24-bit/96kHz audio, simply plug in and play.

In this configuration the DacMagic Plus is able to work at up to 24-bit/96kHz by declaring to your computer that it can handle any sample rate from 32kHz to 96kHz.

However in some Windows/Mac operating system variants the operating system itself may restrict or fix the output sample rate or re-sample the audio.

See our online guide at www.cambridge-audio.com/DacMagicPlusSupport on USB Audio for more details on this. With careful choice of playback software and settings many pitfalls can be avoided.

In particular our free Windows USB Audio 2.0 driver (available from our website) supports up to 24-bit/192kHz audio and WASPI Exclusive or ASIO modes that can give enhanced performance.

A brief explanation of your choices is below:

Switching between USB Class 1 and USB Class 2 operation

Your DacMagic Plus will come set to driverless USB Audio Class 1.0 by default, but it can be configured to run in either USB Class Audio 1.0 or 2.0 mode. To change USB Class, press in the 'Filter/ Phase' button during power up. One of the digital input source LEDs will illuminate to indicate current USB setting: Digital 1 represents USB Audio Class 1.0, likewise Digital 2 is USB Audio Class 2.0. USB Class is selected by turning the Volume knob, once set simply press the Volume knob and DacMagic Plus will restart in your chosen mode.

Use with PCs

With the DacMagic Plus switched to USB Audio 1.0 (this is the default setting) the DacMagic Plus will work with the native Windows XP, Vista or 7 Audio 1.0 driver (no need to load any new driver) and accept audio up to 24-bit/96kHz.

With the DacMagic Plus switched to USB Audio 2.0 the DacMagic Plus needs the Cambridge Audio USB Audio 2.0 Driver to be loaded and can then accept up to 24-bit/192kHz (and support ASIO and WASAPI Exclusive if required).

The driver is available from www.cambridge-audio.com/DacMagicPlusSupport.

Use with Macs

No extra drivers are required. With the DacMagic Plus switched to USB Audio 1.0 the DacMagic Plus will work with the native Mac OS-X 10.5 (Leopard) or above Audio 1.0 driver and accept audio up to 24/96kHz.

With the DacMagic Plus switched to USB Audio 2.0 the DacMagic Plus works with the native Mac OS-X 10.5 (Leopard) or above Audio 2.0 driver and can accept audio up to 24/192kHz.

Use with Linux

For most builds of Linux with the DacMagic Plus switched to USB Audio 1.0 the DacMagic Plus will work with the native Audio 1.0 driver and accept audio up to 24-bit/96kHz.

Some very new builds of Linux are now supporting USB Audio 2.0 for which the Dacmagic Plus should be switched to Audio 2.0 support to accept audio up to 24-bit/192kHz.

For both cases because Linux builds vary according to their creators choice of software components including drivers it is not possible to guarantee operation and Audio drivers may need to be loaded.

'Class drivers' as they are called for generic support of Audio Class 1.0 or Audio Class 2.0 devices may be available from the Linux community, we do not supply these.

Bit perfect transfer – ASIO and WASAPI Exclusive mode

The DacMagic Plus USB interface hardware and software support bit perfect transfer.

Whether or not the audio sent to the DacMagic Plus is bitperfect (i.e. not resampled or mixed etc. by the PC) is actually a function of the playback application and the operating systems audio engine.

By default the standard windows audio drivers (often called WDM drivers) included in Windows XP support MME or DirectSound transfer, both of which include a kernel mixer and re-sampler stage.

One way round this is to use ASIO to bypass this. Another is to use a playback application that supports its own form of kernel streaming, i.e. if has its own way of outputting the audio without invoking the kernel mixer.

For Windows Vista and Windows 7 a new method of audio transfer is supported called WASAPI. This has two modes; Shared and Exclusive. Shared mode is similar to MME or DirectSound but in Exclusive mode the kernel mixer/re-sampler is bypassed and bit perfect transfer is possible with only one audio playback program directed to the soundcard at a time (for instance system sounds are not mixed in).

To ensure bit perfect transfer use a playback application that supports ASIO, WASAPI in Exclusive mode (if you have Windows Vista or Windows 7) or some form of kernel streaming.

This is a fast moving area so we would encourage you to check the web for the latest media players to support these more audiophile playback options.

To use ASIO you will need the Cambridge Audio Sound Driver installed and the DacMagic Plus switched to USB Audio 2.0.

No further settings are required as the driver automatically supports ASIO transfer, all that is required is to load and setup suitable ASIO enabled playback software.

ASIO (Audio Stream Input/Output) is a non Microsoft audio driver protocol for Windows originally invented by Steinberg ltd ASIO bypasses some of the normal audio path from the playback application through the Windows audio system (including the Kernel Mixer) for a more direct path to the DacMagic Plus.

You will need to install and use a suitable playback application that supports ASIO output either natively or via a plugin. One example of such an application with a suitable plugin is FooBar, see <http://www.fooBar2000.org> for more details.

Digital audio output connections

Note: Do not turn on the unit until all connections have been made.

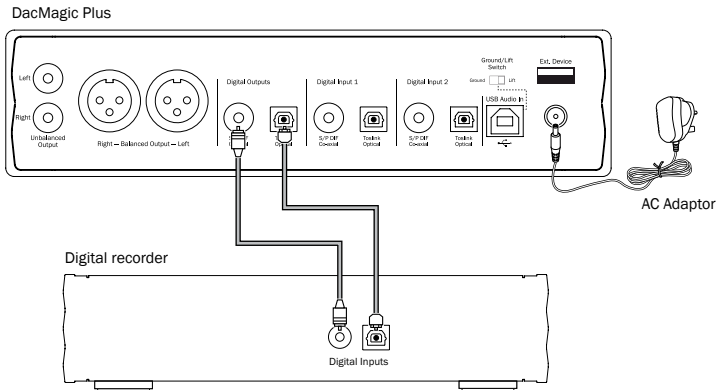

If it is desired to loop out the currently selected digital audio for recording on a suitable device (MD, CD-R, etc.), you can connect either an S/P DIF co-axial or TOSLINK optical cable to the digital outputs as shown, each type being of equal quality. Both output types are active concurrently and both can be used simultaneously to run equipment.

Note: There is no upsampling performed on the digital output pass-through.

Optional BT100 Bluetooth adaptor (not supplied)

When connected to your Dacmagic Plus this adaptor allows the DacMagic Plus to receive BluetoothAudio (known as Bluetooth Advanced Audio Distribution Profile or A2DP). Contact your dealer for details.

The BT100 supports Bluetooth A2DP using either the original SBC encoded form or the latest higher quality apt-X encoded form.

SBC and apt-X refer to the encoding used over the wireless Bluetooth interface only and not the format your music may be in, which can be any type that your phone/laptop or other playing device supports.

Your playing device plays your files then re-encodes the playback before streaming it to the BT100 in one of these two formats.

Many phones and laptops now feature Bluetooth with A2DP. SBC should be supported by all such devices (it is the mandatory format for A2DP).

apt-X is optional, so check if your sending device supports it, if you wish to achieve the highest quality audio transfer.

Note: The BT100 declares that it can handle both SBC and apt-X to the sending device which will then use whichever version it supports.

What is apt-X?

apt-X is a high quality CODEC (CODer/DECoder) i.e. a way of compressing audio data so it can be sent over a link such as Bluetooth then decompressed on the other side (if both devices support it).

If your Bluetooth audio source does not support apt-X, the BT100 will fall back to using the standard SBC CODEC that is supported by all Bluetooth audio devices.

BT100 controls and connections

A. Pairing button/Status LED

Button performs pairing and related functionality. Integrated LED indicates BT100 status.

B. USB plug

Streams high quality USB audio into your DacMagic Plus Ext. socket.

C. Extension Cable

Allows the BT100 to be positioned for accessibility or optimal wireless reception.

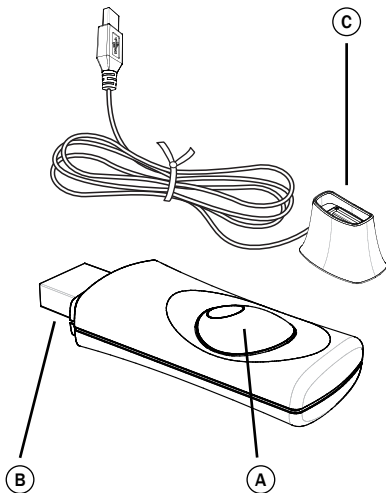

Operating instructions

First select the EXT. source on DacMagic Plus then follow the steps below.

Pairing

To begin streaming high quality music from your chosen media source it will first need to be paired with the BT100.

- A. Insert BT100 into the Ext. USB port at the back of your DacMagic Plus.
- B. Wait a moment for the BT100 to be detected. Then double click the button to enter pairing mode, the BT100 indicates it is in the pairing state by flashing rapidly.
- C. Put your Bluetooth compliant audio source into pairing mode. Please consult your manufacturer's user manual on how to do this.

Pairing your BT100 and source establishes an authorised audio link that can then be used again in the future without having to go through this stage again.

After pairing you can just select the BT100 and play at any time as long as your Bluetooth A2DP compatible source (phone/laptop etc.) is within approx. 10m of the BT100.

Normally on your source you will need to select Bluetooth Pairing and then the BT100 should appear as 'Cambridge Audio BT100' in a list of locally found Bluetooth devices.

Select that item in the list to finish pairing.

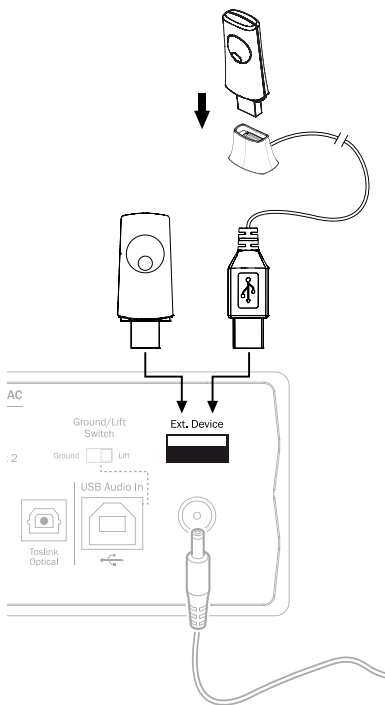

D. On successful pairing, the BT100s LED goes off for a second or two, then triple flashes quickly. The LED then goes off and only lights up in the future when you are playing audio via Bluetooth.

E. To play back via a paired Bluetooth device, simply select the BT100 on that device and start playing. The BT100 LED lights up constantly when streaming SBC or on and flicks off every 2 seconds when streaming apt-X.

Notes:

- You can pair to more than one source up to a maximum of 8 sources at any time. Pairing to a 9th device will cause the first one to be forgotten and so on. However as you would expect the BT100 can only play back from one of these sources at a time.

- When you have finished playback many sources keep the Bluetooth link active for a time unless you actively tell them to stop by deselecting playback via the BT100 (do not unpair as this is not necessary).

This can prevent another source to be able to access the BT100.

To immediately use another source, simply deselect the BT100 for playback on your first source device before starting up on a second.

- Some devices stream empty data all the time even when paused or stopped. These devices will cause the BT100s LED to be on even if playback is currently stopped or paused.

Operating instructions

The DacMagic Plus can be sited in two different positions, as shown in the accompanying diagram. It can be placed horizontally by fitting the four small individual feet, or vertically by using the large rubber 'foot'. Power on the DacMagic Plus using the On/Off button on the front panel. After 4-5 seconds, the unit will unmute and the current Source and Filter type will be shown by the front panel LEDs. Using the Source button on the front panel, select the appropriate digital input, i.e. USB, Digital 1, Digital 2 or Ext, that you wish to listen to.

Switch on the external source, e.g. CD player, DVD player, etc. The sampling frequency of the Digital Input will be displayed on the front panel (e.g. for a CD player – 44.1kHz). Momentarily press the Filter/Phase selector button to cycle between three different filter modes. Start playback of the source equipment. The DacMagic Plus will output analogue audio from the Unbalanced/Balanced outputs upsampled to 24-bit/384kHz. A 'raw' S/P DIF co-axial and TOSLINK optical digital output is also provided. These outputs can be used to connect a compatible digital recorder, e.g. CD-R/MD, etc.

The DacMagic Plus is compatible with Digital Stereo LPCM of a sampling frequency between 32-192kHz.

Note: Being a stereo device, this unit does not decode 5.1 Dolby Digital or DTS Bitstreams from a DVD player, etc. When receiving a multi-channel digital input, the analogue audio outputs are muted. However, a 5.1 DD or DTS Bitstream will pass-through to the digital outputs

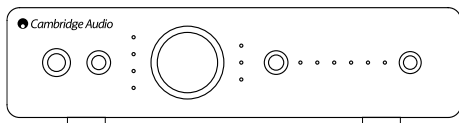

Horizontal placement

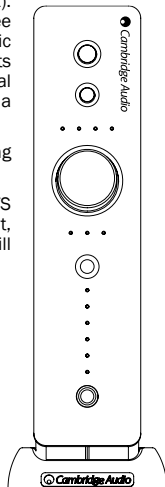

Vertical placement

Filters

The DacMagic Plus DSP has three different Filter functions: Linear Phase, Minimum Phase and Steep. All three filters are highly sophisticated audiophile topologies, optimised specifically for audio playback. In our opinion, these filters offer excellent sound quality but differ subtly in optimisation, hence we've made all three available to you.

Note: For clarity, all diagrams show the theoretical response of the DSP itself, excluding any analogue filtering at the DAC output or the anti-aliasing filter applied during recording and/or mastering of the digital source.

Linear Phase Filter

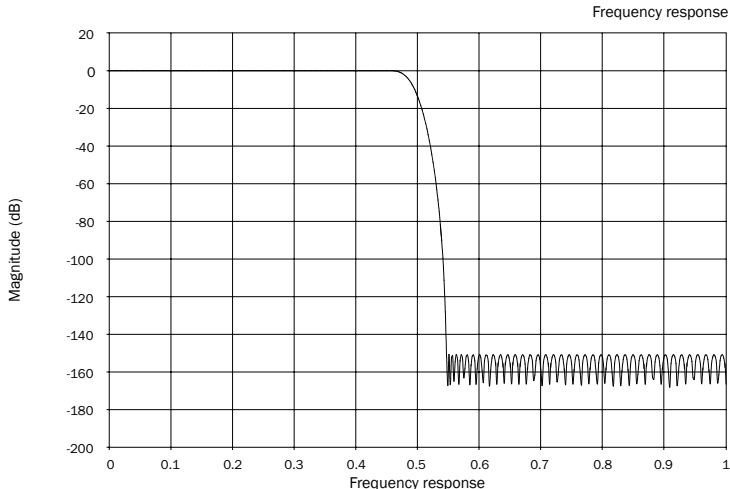

The Linear Phase filter is a highly regarded audio filter offering low ripple in both the pass and stop bands, and what is known as constant group delay. Constant group delay means that audio signals of all frequencies are always delayed by the same amount when passing through the filter. All audio is therefore fully time-coherent at the output.

The trade-off with this type of filter is that due to internal feed-forward in the DSP, its impulse response will exhibit some pre-ringing. In other words, when excited with a theoretical impulse, the output has both a small amount of pre- and post-spike amplitude ringing (albeit well damped).

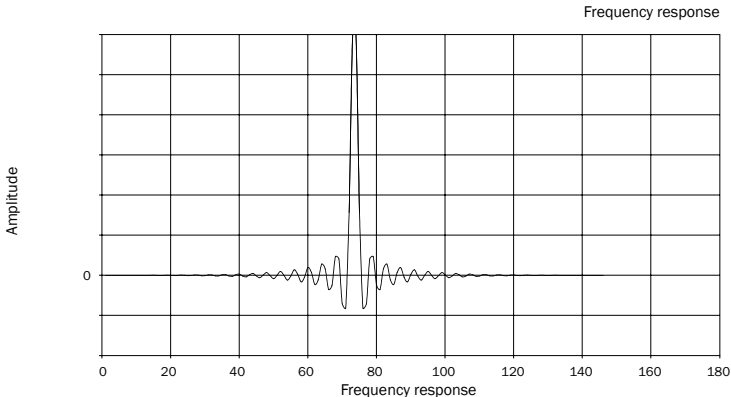

Minimum Phase Filter

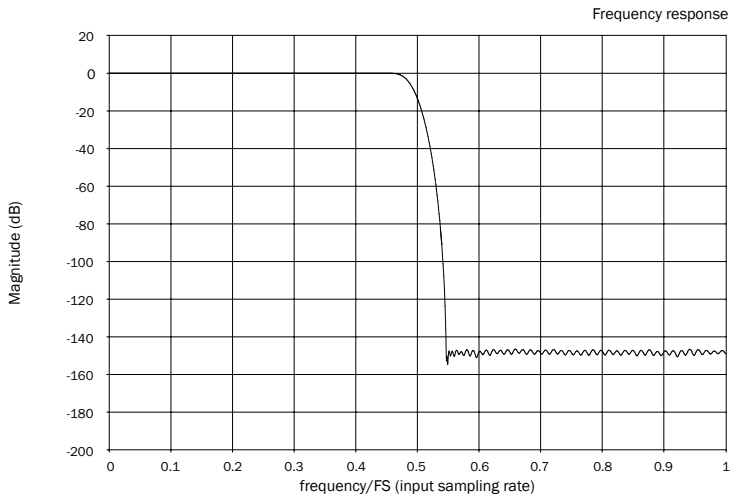

The Minimum Phase filter is another highly regarded audio filter that offers even lower ripple in the pass and stop bands. Unlike the Linear Phase filter, group delay is not constant so some time-coherence is lost; however, phase shift is low and the particular benefit with this filter is that the impulse response exhibits no pre-ringing.

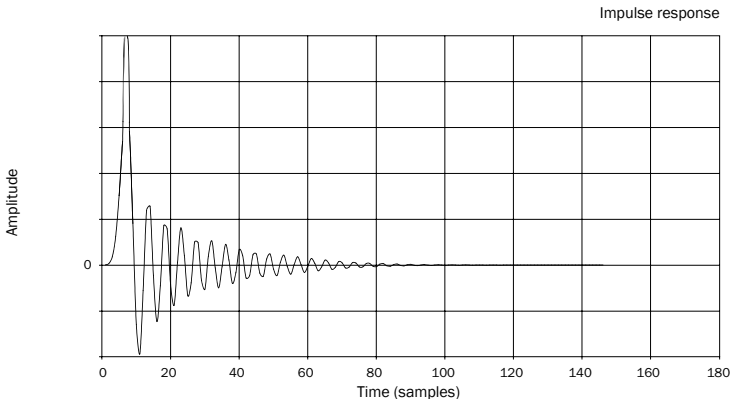

Step Filter

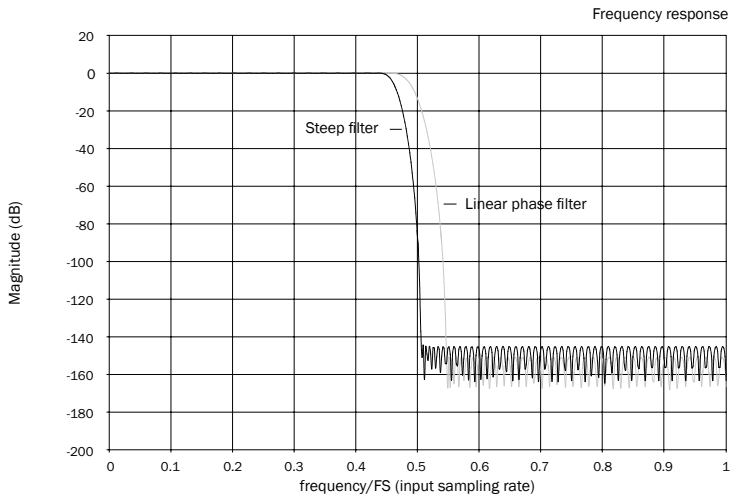

Our Steep filter is a linear phase filter that has been optimised for stop band attenuation of close-in aliasing images. Here we have traded a little attenuation of the very highest frequency response (-2dB at 20kHz) and a little more pre- and post-ringing for a very steep attenuation just outside the pass band. The Steep filter is able to attenuate aliasing at 22kHz by some 80dB.

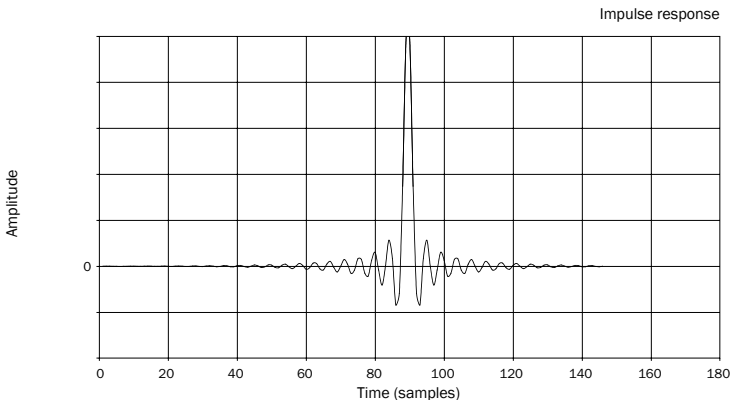

Note: All filters exhibit the same ultimate roll-off of approximately 140dB.

The following table shows the filter stop band attenuation:

	Linear Phase	Minimum Phase	Steep
Roll-off at 20kHz	-0.1dB	-0.1dB	-2dB
Roll-off at 22kHz	-10dB	-10dB	-82dB
Ultimate roll-off	140dB	140dB	140dB

We encourage you to experiment with the filters to determine which sound best to your ears and using your source equipment/programme material. The DacMagic Plus remembers and recalls the selected filter type for each input individually, making it possible, for example, to select Steep for the USB input and Linear Phase for Digital Input 1, and so on.

Technical specifications

D/A converters	Dual Wolfson WM8740 24bit DACs
Digital filter	Analog Devices ADSP21261 DSP upsampling to 24-bit/384kHz
Analogue filter	2-Pole Dual Differential Bessel Double Virtual Earth Balanced
Frequency response	20Hz to 20kHz ($\pm 0.1\text{dB}$)*
THD @ 1kHz 0dBFs	<0.001% 24-bit
THD @ 1kHz -10dBFs	<0.001%
THD @ 20kHz 0dBFs	<0.002%
S/N ratio	-112dB _r
Total correlated jitter	<130pS
Crosstalk @ 1kHz	< -130dB
Crosstalk @ 20kHz	< -112dB
Output impedance	<50ohms
Max output level (unbalanced)	2.1V rms
Max output level (balanced)	4.2V rms (2.1V per phase)
Digital input word widths supported	16-24bit
Digital input sampling frequencies supported	32kHz, 44.1kHz, 48kHz, 88.2kHz, 96kHz, 176.4kHz**, 192kHz
Audio output upsampling	Fixed 24-bit/384kHz
Max power consumption	12W
Dimensions (H x W x D)	52 x 215 x 191mm (2.0 x 8.6 x 7.6")
Weight	1.2kg/2.6lbs

* Steep filter disabled

** Digital 1 & 2 Inputs only

Troubleshooting

There is no power

Ensure the supplied AC adaptor is connected securely to the PSU socket on the rear panel.

Ensure that the correct mains transformer is being used and that it complies with the local electrical supply.

Ensure the mains plug is fully inserted into the wall socket and is switched on.

There is no sound

Ensure that the amplifier is set correctly. Check that the interconnects are inserted correctly. Check that the correct digital input is selected (Incoming Sample Rate LED should be on).

A low hum or buzzing sound can be heard

Power cords or lighting placed near this product. Analogue inputs are not securely connected.

For USB try selecting the 'Lift' position by moving the Ground/Lift switch.

Cambridge Audio is a brand of Audio Partnership Plc
Registered Office: Gallery Court, Hankey Place
London SE1 4BB, United Kingdom
Registered in England No. 2953313

www.cambridge-audio.com

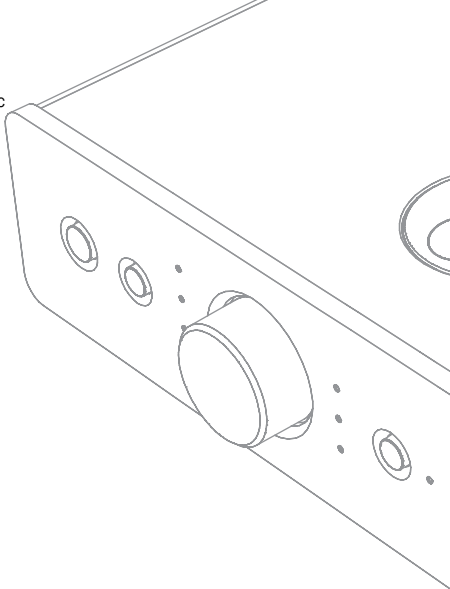

© 2011 Cambridge Audio Ltd

AP30837/1-A